



Stögra Antriebstechnik GmbH

Machtlfinger Straße 24
D-81379 München

Tel.: (089)15904000

Fax.: (089)15904009

info@stoegra.de

<http://www.stoegra.de>

WSERS

Version V01

Stepping motor power amplifier board
with position control and RS232/RS485 interface

Installation and programming manual

Edition December 2006

All rights reserved.

Without written approval we allow no reprint nor partial copying.

We reserve the right to make engineering changes, refinements and improvements.

Mechanical and electrical ratings and dimensions are, therefore,
subject to change without notice.

No liability whatsoever is accepted.

Index

	page
1. General notes	
1.1 Safety rules.....	4
1.2 General notices WSERS.....	4
1.3 Installation.....	6
2. Connections, power supply and dimensions	
2.1 Connections.....	7
2.2 Limit-/ home-/ stop-/ and external service switch.....	8
2.3 Ready Signal.....	9
2.4 Power supply.....	10
2.5 Separated external logic power supply – Option "U".....	11
2.6 Dimensions.....	12
3 Positioning control	
3.1 Configurations via DIP-switches.....	13
3.1.1 Drive address.....	13
3.1.2 Baud rate.....	14
3.1.3 Enable manual drive functions/ service switch	14
3.1.4 Signal level and polarity of inputs.....	14
3.1.5 Automatical program start.....	14
3.2 Interface RS232C/V24 and RS485	
3.2.1 Configurations.....	15
3.2.2 9-pole D-Sub-connector.....	15
3.2.3 Connection PC-SERS and SERS-SERS.....	15
3.3 I/O-Port with digital inputs and outputs	16
3.4 Optional encoder input.....	18
3.5 Status-/error indication - 7-Segment indication....	19
3.6 Operation modes - Overview	
3.6.1 Serial mode.....	20
3.6.2 Master mode.....	20
3.6.3 Parallel mode.....	20
3.6.4 Standalone mode.....	20

	page
4. Programming and operation of the SERS	
4.1 Syntax general notes.....	21
4.2 Syntax definitions.....	22
4.3 Program lines numbering.....	26
4.4 Limitations for E ² PROM-programs.....	26
4.5 SERS functions and modes	
4.5.1 Manual operation - manual drive.....	27
4.5.2 Operation in master mode, parallel mode and standalone mode.....	27
4.5.3 Programming mode.....	30
4.5.4 Trace mode.....	30
4.6 Programming commands	
4.6.1 IF : conditional execution.....	30
4.6.2 Labels.....	31
4.6.3 GOTO, GT : jump.....	32
4.6.4 GOSUB : subroutine call.....	32
4.6.5 RETURN : subroutine termination.....	32
4.6.6 Programming of positioning jobs.....	33
4.6.7 Positioning with velocity profiles - polynom function.....	34
4.6.8 WAIT instruction.....	35
4.6.9 “ : “ instruction - manual driving until STOP..	35
4.6.10 Arithmetical functions in the WSERS.....	36
4.6.11 Operation with the SERS-Programmer.....	36
4.6.12 Program examples.....	37
4.7 Parameter overview.....	39
4.8 SERS parameters.....	41
5. Technical specifications.....	76

1. General notices

1.1 Safety rules

The stepping motor drives WSERS are designed for the installation into other devices or machines or for mounting together with other devices or machines.

The operator of the WSERS has to ensure that all installation-, maintenance-, mounting- and inspection works at the WSERS are carried out **only from qualified and authorised professionals**, who informed themselves by a detailed study of this manual.

The operator is responsible, that all installation-, mounting-, maintenance - and inspection works are carried out correctly.

The manufacturer rejects any liability for mistakes or damages because of not correct installation or not proper handling.

The WSERS may not be commissioned, as long as it is not built into a device, which corresponds to the specifications of the norm VDE 0100 part 410 – protection against dangerous currents through human bodies – and VDE 0100 part 420 – protection against thermal influences.

At any installation-, maintenance-, mounting- and inspection works the WSERS first has to be separated **from all electric circuits**. There may not be any electricity at the device (**must be verified !!!**) !

1.2 General notes SERS

The WSERS is a **stepping motor power amplifier board with integrated control of position and RS232C (COM – V24) or optionally with RS485, Profibus-DP or CANopen –Interface** (WSERS must be ordered with one of the interfaces).

The unit controls **2-phase stepping motors** with phase currents from 0 to 4,2 ampere / phase (WSERS 04) or 0 to 6 ampere / phase (WSERS 06) or 0 to 8,4 ampere / phase (WSERS 08).

WSERS is designed in a modular way with three levels (realised with three PCB's connected via PCB-connectors).

The lowest level is the power amplifier. Here the phase currents are created within two H-bridges.

The second level controls the phase currents (control of the microstepping and commutation of the phase currents).

The upper level consists of the position control and an interface (see options above).

The **power amplifier** of the SERS features :

- control of 2-phase stepping motors by using the bipolar chopper-principle.
- microstepping with a resolution of 12800 steps per revolution
- protection against short circuit (in the motor : phase to phase and phase to GND-earth)
- protection against over temperature and under voltage
- phase currents from 0 to 4,2A and a power supply of 20 to 80VDC (WSERS 04.80), and 0 bis 8,4A at 20 to 80 VDC (WSERS 08.80), 0 to 4A at 230 VAC (WSERS 04.230AC – with internal 325VDC), 0 to 6A at 230 VAC (WSERS 06.230AC – with internal 325VDC)

The **control of motor velocity and position** features :

- acceleration : 2 rad/s² to 15600 rad/s²
- velocity : 0,12 rev/min to 12000 rev/min (motor – depending on size – can be operated until 4000 rev/min)
- position : - 2³¹ increments to + 2³¹ increments
- control of limit switches and homing

Die **RS232/RS485 - interface** features:

- selectable baud rates from 1200 to 115200 Baud.
- 8 data bits / no parity / 1 stop bit
- handshake : V24 - RTS/CTS – hardware handshake (can be disabled via software)

The **functional principle of the position control** is as follows:

- internal operation-cycle 0,5ms – that means independent of an existing operational program every 0,5ms all external inputs are controlled, feedback signals of the power stage are controlled, various parameters are checked, received characters at the serial input buffer are evaluated, ... – similar to the working principle of a PLC
- an operational program in the E²Prom is executed line by line. (functional principle as a CNC-control). The control stays at every command in the program lines until the command is finished. Except the commands 'start positioning' (E), 'start homing' and 'delay' (D) all commands are being executed within one internal operation cycle (0,5ms).

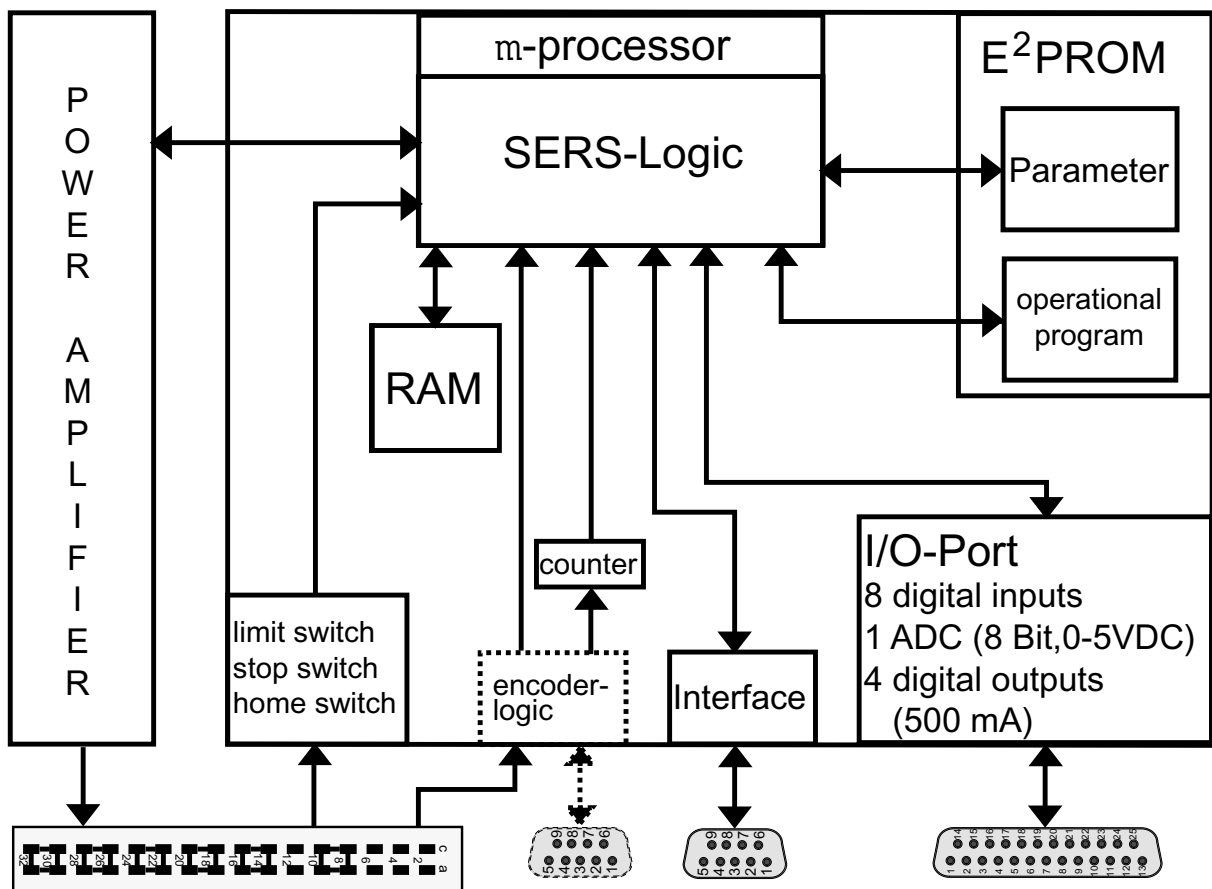

WSERS shown with function blocks

1.3 Installation

Before doing any installation-, maintenance-, mounting- or inspection work pay attention to the safety rules (this manual chapter 1.1) !!!

All relevant standards of the low voltage-, EMC- and machine directives must be fulfilled before commissioning the WSERS !!!

Leads/cables to the stepping motor:

Shielding:

The cables of the WSERS to the stepping motor should be shielded, for preventing noise radiation.

A shield made of metal braiding achieves better results, than a shield made of metal foil. The shield should be mounted on a large surface at both sides (motor and case or cabinet in where the WSERS is installed).

Leads cross section:

The following table shows reference values for choosing the right cross section.

The values in the table refer to a standard leads type, e.g. flexible PVC control leads with copper-shield braiding.

By using different types of leads, we reference to the standard VDE 0298 part 4.

motor current [A]	cross section [mm ²]
until 4	0,75
until 6	0,75 to 1,0
until 10	1,0 to 1,5
until 16	1,5 to 2,5

Ground conductor system:

The ground conductor system must be installed correctly (VDE 0113).

Herefore it is important e.g.:

- The ground clamp inside the motor must be connected.
- The GND-connection of the power supply for the WSERS must be connected to ground direct at the power supply (in case of long leads between the power supply and the supplied device – WSERS).

Ground conductor (PE) connection at ELK – panel mount systems:

Connect the connectors 'PE', 'GND (of 24 VDC)' and 'GND (of VCC)' – three connectors direct beside each other, located direct beside the mains connection (PE, L1, N) – to your ground conductor (PE) bar inside your switch cabinet.

If there is no switch cabinet respective no PE bar, then connect the 3 connectors 'PE', 'GND (of 24 VDC)' and 'GND (of VCC)' to each other with short 1,5mm² leads.

Protection against touching:

The WSERS must be installed in a way, that there is no danger (electrical shock) when being touched (VDE 0113).

2. Connections, voltage supply and dimensions

2.1 Connections

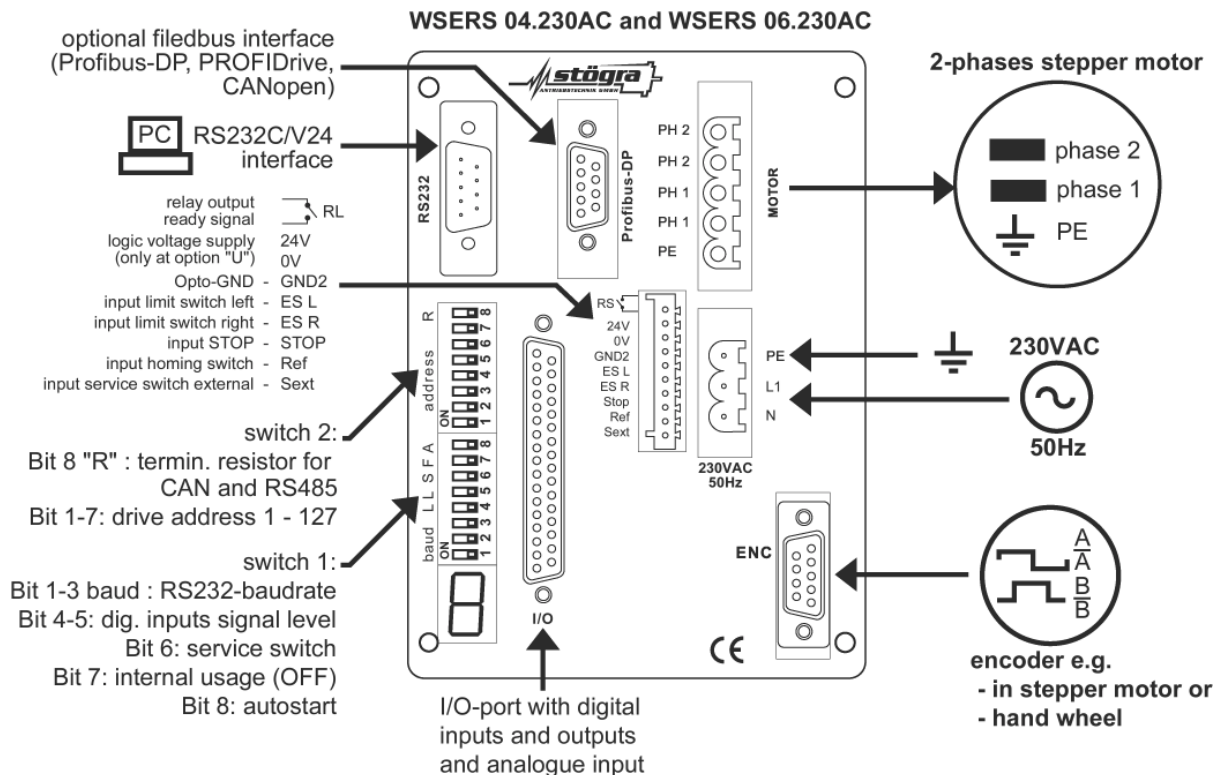
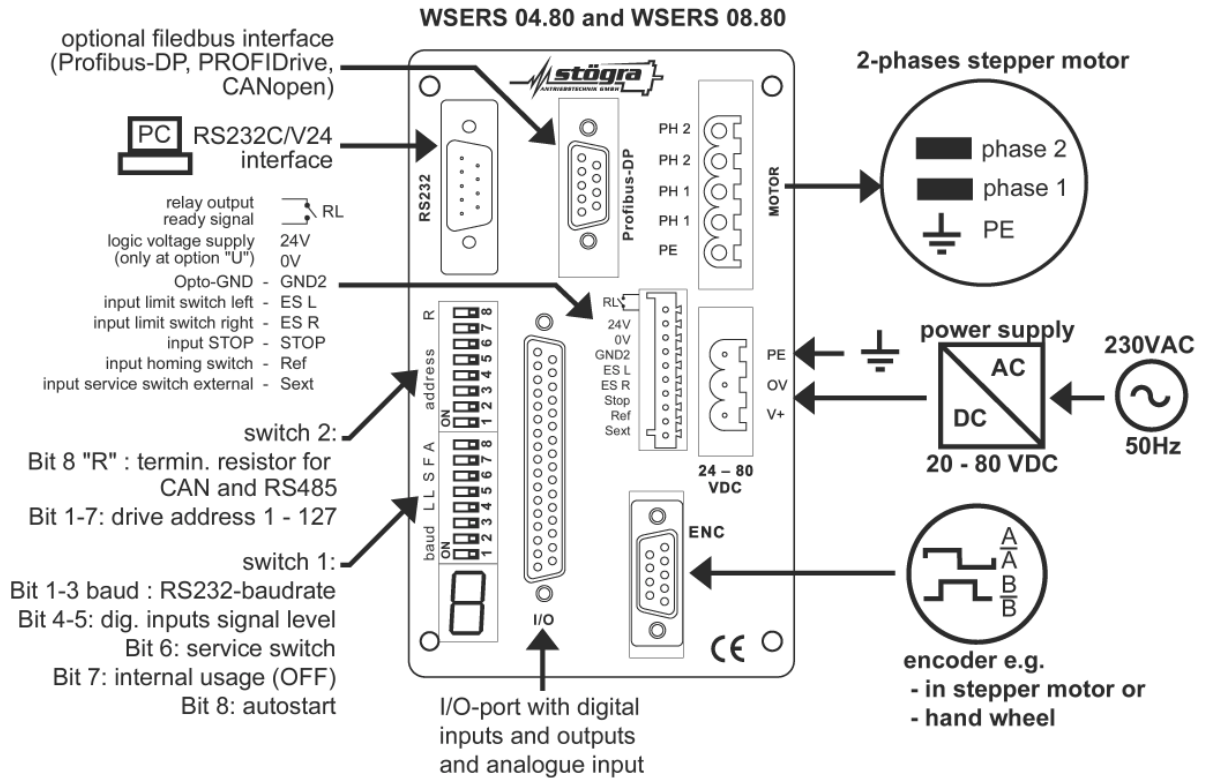

2.2 Limit-/home-/reset-/stop-/ and external service switch

The two limit switch-inputs, the home switch-input, the reset-input and the stop-input are optoisolated 24 VDC inputs.

The connection **GND2 (Opto-GND)** is the 0V (common GND) of these signals.

This connection is not connected to any other potential in the WSERS. Therefore the **GND2** connection must be connected to the 0V of the external 24V for the stop- and limit switches.

The two **limit switch-inputs** and **the stop-input must** be connected for the operation of the WSERS! Meaning that for operation there must be 24 VDC at both limit switch inputs and at the stop switch input, in case the motor is not on a limit switch position or in case there is no stop active. Otherwise the unit returns the message 'position overflow' and the 7-segment display indicates a 'c' (open limit-switch) or it returns the message 'stop input open' and the motor cannot be moved.

If STOP- and limit switches are not used at all, then these inputs maybe inverted by setting parameter P1038=2 (connecting the inputs to 24VDC then is not necessary anymore).

The **home switch-input** is used for the drive controlled homing procedure. A 24 VDC voltage level at the home switch-input means, that the home position is reached (the motor is on the home position).

The **input external service switch** is for enabling the manual drive functions at the digital inputs I 1 to I 8 (the parameter P1092 must be set "1" additionally). A 24 VDC level at the external service switch input means, that the external services switch is active and the manual drive functions are enabled.

The following electrical schematics shows the input circuits at the WSERS.

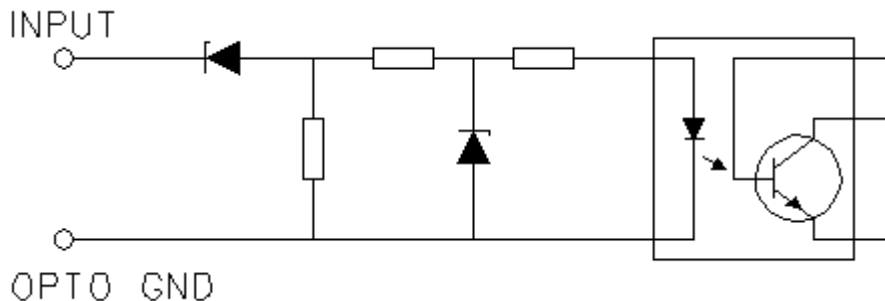

Voltage range inputs: 13 VDC – 30 VDC !

With a connected limit switch the electrical schematics is as follows (motor not on limit switch position) :

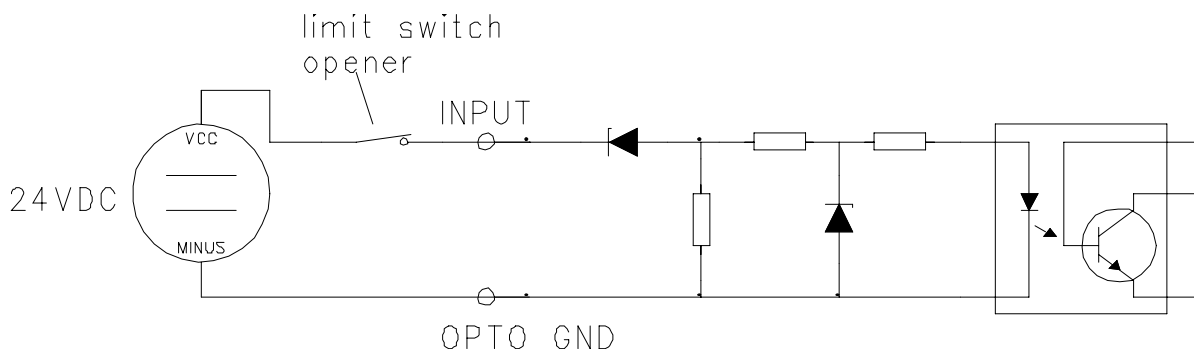

Both limit switches and the stop switch must be break contacts (opener) !!!

The home switch and the reset switch must be make contacts (closer) !!!

2.3 Ready signal - relay to control a brake

The output „ready signal“ is e.g. for controlling an emergency brake at the motor (especially for Z-axis).

The signal indicates that the motor phase current is switched on.

Attention ! The output can not control the brake directly. There must be used an additional power relay! (Alternatively the brake can be controlled directly from one of the WSERS outputs O1 – O4 – see parameter 1036)

Stepping motors with integrated brake usually have permanent magnet brakes, which will be activated in case of loss of power.

The connections for the ready signal are located at the 12-pole WSERS connector (see chapter connections at page 7). The **relay contacts** will be **closed** when the **motor current** is switched **on** (command “ON” or in manual (jog) mode via the inputs I1 until I6).

The **relay** contacts will be **open** in case of switching **off** the **motor phase current** by a command (“OFF”), or in case of an **error** (electrical error, mechanical error - encoder feedback error / only with installed option encoder - , or other errors like a limit switch error - see parameter P11) - which will switch off the motor current automatically.

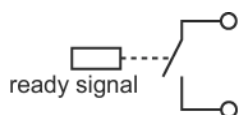

Maximum load at the relay contacts : 50 VDC / 100mA

Attention : When connecting the relay contacts to an external circuit the **maximum load of the relay has to be followed (see above).**

Especially when connecting an inductive load (e.g. small brake), due to the working inductance of the load there must be installed a recovery diode !!!

In non disturbed condition (ready signal active – motor phase current is ON) the **relay contact is closed.**

Following conditions cause disabling the ready signal and an **open relay** :

1. a drive error (see parameter P11) is active
2. the WSERS did not receive the command ON or the last command received is OFF

In the case of any error - except short circuit - the drive will be stopped controlled, meaning that the motor will be decelerated until motor stand still. Then the relay contacts will be opened. Afterwards the phase current will be switched off.

In case of a short circuit the phase current will be switched off immediately and at the same time the relay contacts will be opened.

2.4 Power supply

The **WSERS 04.80** and **WSERS 08.80** require a DC voltage supply. The unit includes an electrolytic capacitor, which is calculated for buffering a **non controlled DC-voltage** with a **ripple of maximum 5%**.

In case of **power supply leads > 0,5 m** (distance between power supply and WSERS), at the input of WSERS (connections see 2.1 page 7) there has to be installed an **additional electrolytic-capacitor with at least 1000 μ F**.

The WSERS 04.230AC / WSERS 06.230AC can be connected directly to the mains 230VAC (50 - 60Hz), the WSERS 04.115AC / WSERS 06.115AC can be connected directly to the mains 115VAC (50 - 60Hz).

Following voltage values are defined :

1. U_V = Maximum voltage supply = nominal voltage supply
2. U_W = Voltage level for the indication of 'pre-warning undervoltage'
3. U_B = Voltage level for the indication of 'error undervoltage'
4. U_L = Voltage level for switching off the power amplifier internally

	U_V [VDC]	U_W [VDC]	U_B [VDC]	U_L [VDC]
WSERS XX.80	80VDC	19VDC	18VDC	16VDC
WSERS XX.230AC	325VDC	162VDC	140VDC	126VAC
WSERS XX.230AC	230VAC	115VAC	100VAC	90VAC
WSERS XX.115AC	162VDC	81VDC	70VDC	63VAC
WSERS XX.115AC	115VAC	58VAC	50VAC	45VAC

U_V :

The maximum voltage supply U_V is calculated for a maximum mains tolerance of + 15%. That means, that the non controlled DC-voltage output of the power supply, which is used for the **voltage-supply** for the WSERS, **may have nominally maximum 85 VDC but not 85 VDC + 15% !**

U_W

If the supplied voltage becomes lower than U_W , then a message 'pre-warning undervoltage' will be sent, Bit 15 of P12 (warning parameter) will be set and a blinking '9' will be indicated at the 7-segment display.

U_B

If the supplied voltage becomes lower than U_B then the drive will be stopped, meaning that the stepping motor will be decelerated until stand still.

Then the ready signal will be disabled (output relay contacts will be opened) and 50ms afterwards the stepping motor phases will be switched off (switching off the motor torque). A message 'error undervoltage' will be sent, Bit 9 of P11 (error parameter) will be set and the 7-Segment display will indicate '9'.

U_L

If the supplied voltage becomes lower than U_L then the motor torque will be switched off immediately without decelerating the motor for protecting the electronics of the power amplifier.

The 7-Segment display is as described in U_B .

2.5 Separated external logic supply – option "U"

An separated external logic voltage supply input exists for all WSERS units with option "U" (marking "U" in the type designation, e.g. WSERS 08.80 V01 PB-DP U or WSERS 04.230AC V01 E50 PB-DP U).

The option "U" must be ordered explicitly (no standard feature for the WSERS).

At standard WSERS units (without option "U") the logic section of the WSERS (including microcontroller and interface controller) is supplied by the common main power supply (e.g. in case of a WSERS 08.80 V01 it is the voltage supply 20 – 80VDC, or in case of the WSERS 04.230AC V01 it is the 230VAC). In the WSERS there is an internal DC/DC device which creates the necessary low voltage for the logic from this main voltage.

At WSERS units with option "U" the logic section must be supplied by a separate external 24VDC voltage (connections at the 12 pole screw connector – see chapter 2.1 page 7). When switching off the main voltage (power), in case of a safety power down (e.g. when opening the safety door of a machine), the logic section still is active, and the communication with the WSERS via the interfaces still is possible.

Typically this option "U" is used for WSERS units with Profibus or CAN interface, because here the interface is connected permanently to an interface bus with a master, which needs to communicate with the slaves also after a safe power down of the slaves.

Specification of external logic voltage supply:

Voltage supply : 24VDC (–15% / +10%)

Consumption max. : 100mA

2.6 Dimensions WSERS

WSERS 04.80 and
WSERS 08.80

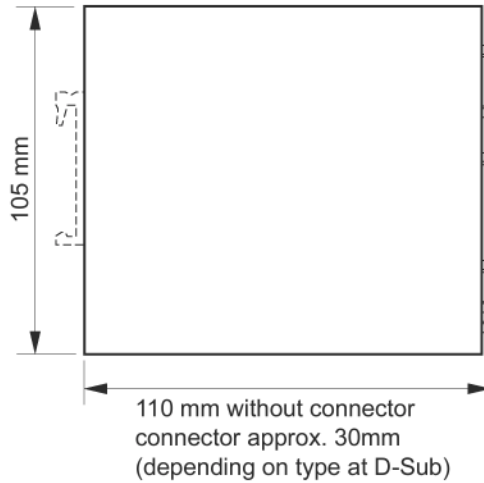
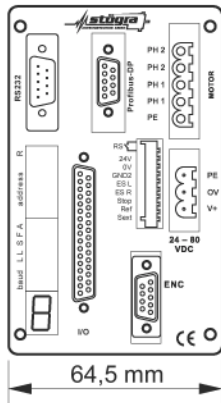

WSERS 04.230AC and
WSERS 06.230AC

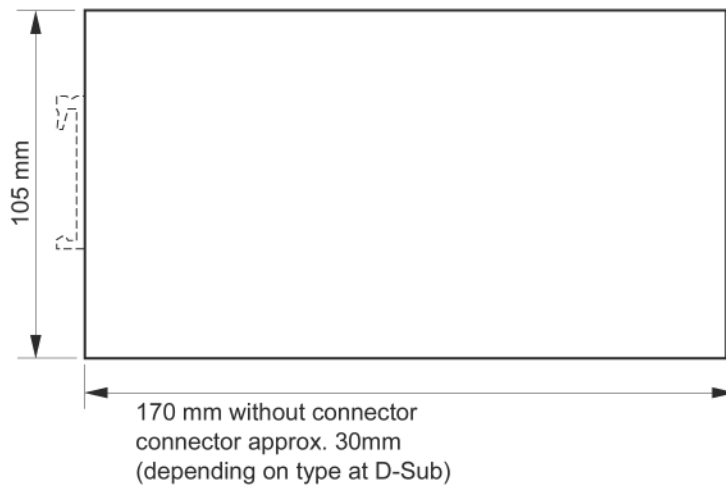
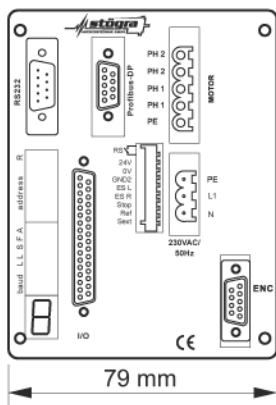

Panel mounting version
WSERS... /W

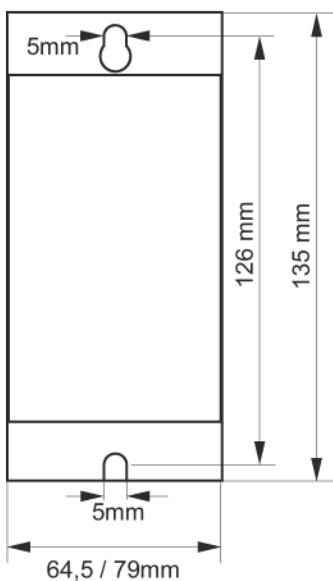

3. Position control

3.1 configurations via DIP-switches

All settings must be made during power-off of the WSERS !

Changings of switches during power on of the WSERS will be ignored – exceptionally bits 4 to 6 of switch 1.

3.1.1 Drive address

The **drive address** (= address of a WSERS slave within a ring of drives) can be selected at the 8 pole DIP-switch 2 (see 2.1 connections) **bits 1 to 7**.

The selected drive address is build with a binary code of the 7 switch positions.

bit	1	2	3	4	5	6	7
value	1	2	4	8	16	32	64

e.g. bit 1 = ON → address = 1
 bit 1 = ON and Bit 2 = ON → address = 3 (= 1 + 2)
 bit 2 = ON and Bit 4 = ON → address = 10 (= 2 + 8)

Possible values for the **drive address** are **1 to 127 for WSERS-Slaves** and the **address 0 for configuring a WSERS as master** (if the master is called with the address 200, then it behaves like a slave and can be programmed).

An ON-position of a switch means a set bit (=1).

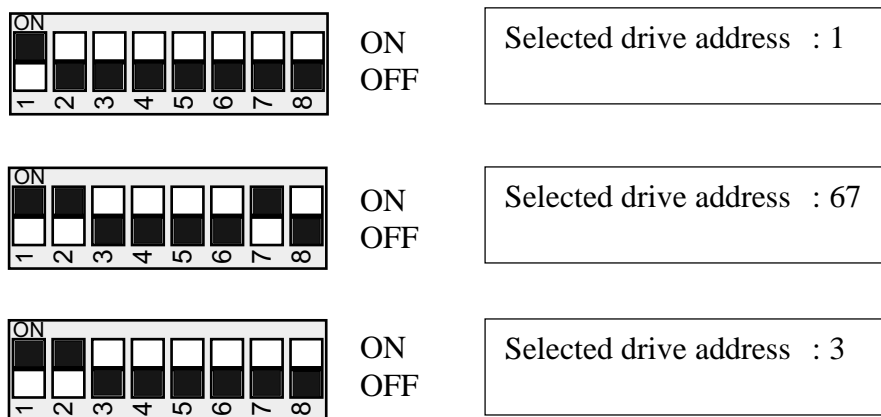

Bit 8 of the 8-pole DIP-switch 2 is reserved for WSERS with RS485 or CANopen interface. With Bit 8 a terminating resistor for the interface is activated.

3.1.2 Baud rate

The baud rate can be selected via bits 1 to 3 of the 8-pole DIP-switch 1 – (see 2.1 page 7 connections).

Baud rate (baud)	1200	2400	4800	9600	19200	38400	57600	115200
Bit 1	OFF	ON	OFF	ON	OFF	ON	OFF	ON
Bit 2	OFF	OFF	ON	ON	OFF	OFF	ON	ON
Bit 3	OFF	OFF	OFF	OFF	ON	ON	ON	ON

3.1.3 Enable manual drive functions

Via **bit 6** of the 8-pole DIP-switch 1 - (see 2.1 connections) – **service-switch** – can be selected, that only the manual drive functions (manual drive right/left/ slow/ fast and start homing) via the digital inputs are enabled. The auto start function and the program start via the serial interface will be disabled.

- bit 6 : ON : all manual drive functions at the inputs enabled
no auto start or start program via serial interface possible
- OFF : manual drive functions at the inputs enabled depending on parameter P1021
auto start and start program via serial interface enabled

For enabling or disabling manual drive functions via parameter P1021 see page 43.

3.1.4 Signal levels and polarity of the inputs

Via bits 4 and 5 of the 6-pole DIP-switch 1 (see 2.1 connections) the signal levels and the polarity of the digital inputs I1-I8 can be configured.

- bit 4 : OFF and bit 5 : OFF : high-active with PLC/SPS-level (13,5 V signal level)
- bit 4 : ON and bit 5 : OFF : high-active with TTL-level (3,5 V signal level)
- bit 4 : ON and bit 5 : ON : low-active (1 V signal level)
- bit 4 : OFF and bit 5 : ON : not valid (may not be selected)

3.1.5 Automatic program start (autostart)

An **automatic program start** can be selected by switching on **bit 8** of DIP-switch 2. In case there is a valid executable program in the E²Prom of the WSERS, then with an ON-position of this switch the program will be started automatically after a Power-On-Reset (= connecting WSERS to power supply).

- Bit 8 : ON : autostart enabled OFF: autostart disabled



ON
OFF

selected baudrate : 19200 Baud
digital Inputs : Low-active
manual drive functions via Inputs enabled
autostart disabled



ON
OFF

selected baudrate : 38400 Baud
digital Inputs : high-active – TTL-level
manual drive functions via Inputs depending on P1021
autostart enabled at Power-ON

Bit 7 of the 8-pole DIP-switch 1 is for internal usage respectively for future function extensions. Bit 7 must be set OFF !

3.2 Interface RS232C/V24

3.2.1 Configurations

Interface configurations for the WSERS:

baud rate : selectable via DIP-switch 1 (see 3.1.2 page 14)

data bits : 8

stop bit : 1

parity : no

handshake : selectable in parameter P1017 – see page 43.

- standard : hardware – pins 7 and 8 at 9-pole D-sub connector
must be connected

3.2.2 Connections 9-pole D-sub-connector

pin

1 : not connected

2 : TXD

3 : RXD

4 : not connected

5 : GND

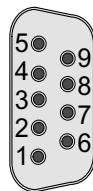

6 : not connected

7 : HSI (hand shake IN)

8 : HSO (hand shake Out)

9 : 9 VDC (power supply terminal)

3.2.3 Connection PC-WSERS and WSERS-WSERS - RS232

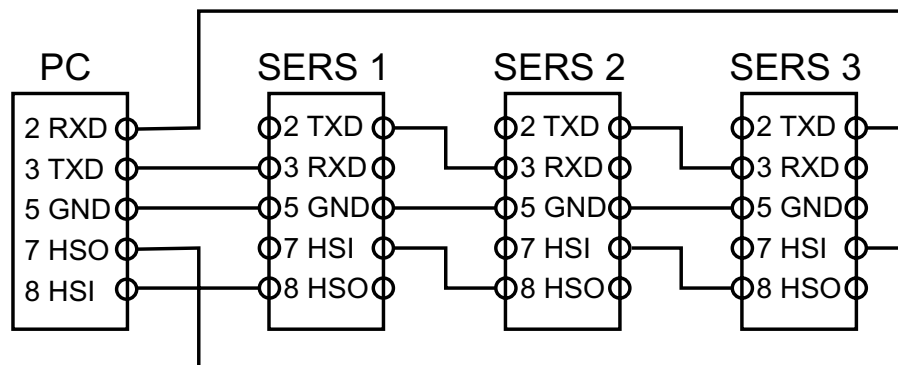

If the hardware hand shake is disabled in parameter P1017 then the pins 7 and 8 are not used !

In standard adjustment the hardware hand shake is disabled !

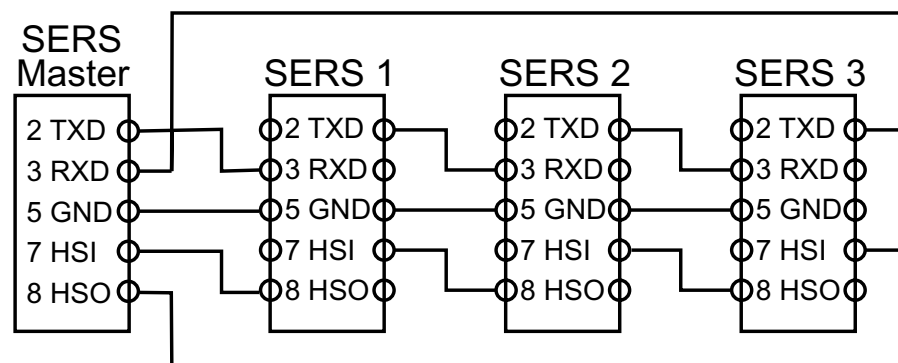

Attention:
PC – WSERS-Slave:
1:1 connection

but

WSERS-Master-
WSERS- Slave:
Zero modem -
connection

3.3 I/O-Port with digital inputs and outputs

3.3.1 Standard I/O-port

All WSERS units include in standard version:

- 8 free programmable digital inputs (**I1** until **I8**) and 4 outputs (**O1** until **O4**)
- 1 analogue input (**ADC**) → at the WSERS xx.230AC / WSERS xx.115AC the analogue input is an option and needs to be ordered extra

The I/Os are connected to the 25-pole D-Sub-female connector, located on the front panel of the WSERS (see page 7).

The inputs can be configured low or high-active and with TTL or PLC/SPS- signal level (see chapter 3.1.4).

The digital inputs and outputs are galvanically insulated (via opto coupler).

At the inputs the connection “GND inputs” (common GND 0V – Pins 13 and 25) must be connected to the external signal GND.

The digital outputs must be supplied externally via the connections “VCC-outputs“ (Pins 1,2,14) and “GND-outputs“ (Pins 5,6,17,18).

The analogue input is galvanically separated only at versions WSERS ...115AC/230AC.

In case of an active service switch (extern and P1092=1 or DIP-switch 1 Bit 6 = ON) the inputs I1 to I8 are assigned to the functions manual drive (jog), start homing, ON/OFF, STOP and START executable program. Else the inputs may be used as free programmable inputs for an executable program (or they may be requested in the serial mode via parameter P1300).

Via parameter **P1021** it is possible to assign just some of the predefined functions to the inputs. The not assigned inputs may be used as free programmable inputs - see also input parameters page 43

Connections standard I/O-port

Pin	connection	Pin	connection
1	VCC outputs	14	VCC outputs
2	VCC outputs	15	output O3
3	output O4	16	output O1
4	output O2	17	GND output
5	GND output	18	GND output
6	GND output	19	do not connect
7	5 VDC output (ADC)	20	analogue input ADC neg.
8	analogue input ADC pos	21	input I7 - Stop
9	input I8 - Start program	22	input I5 - Start homing
10	input I6 - Motor ON/OFF	23	input I3 - Left fast
11	input I4 - Right fast	24	input I1 - Left slow
12	input I2 - Right slow	25	GND input
13	GND input		

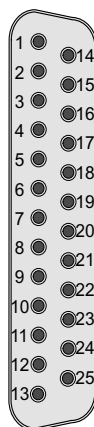

25 pol. D-Sub connector

The 5 VDC output at Pin 7 may be used for supplying e.g. a potentiometer (example at page 17 bottom right). The max. load current is 50mA

Digital Inputs - schematics

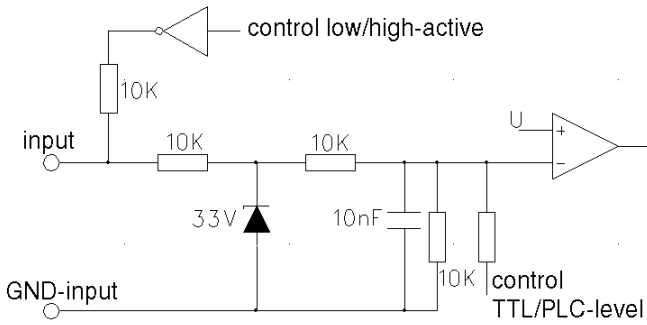

Digital Inputs – signal level

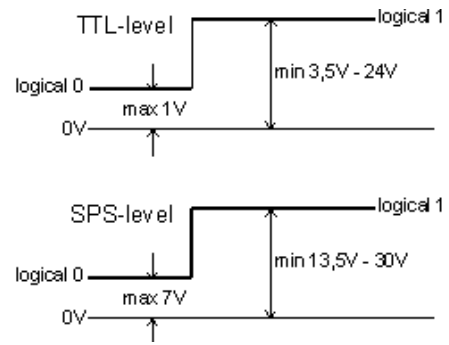

Examples for connecting the digital inputs

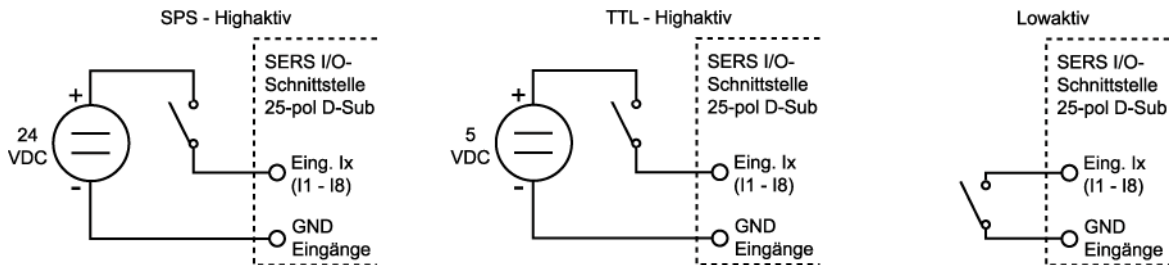

Digital outputs - schematics

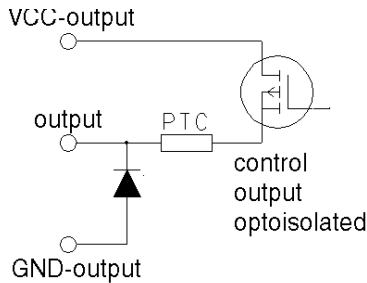

The outputs must be supplied externally by DC-voltage (5VDC - 30 VDC).
When an output is set (e.g. O1=1) then a P-FET will switch through the external supply voltage, a not set output means tri-state.

Connecting outputs (example connecting a motor brake)

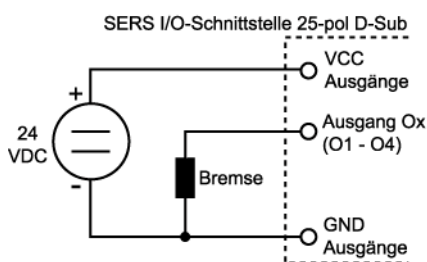

ADC analogue input - schematics

8-Bit analogue input ADC

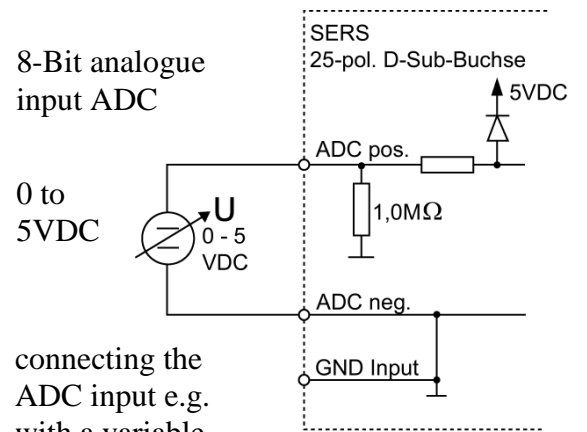

connecting the ADC input e.g. with a variable power supply

or with a potentiometer

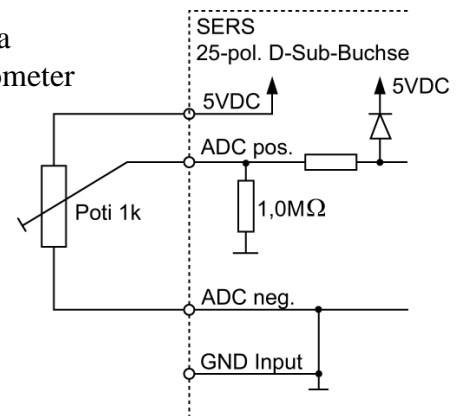

3.4 Optional encoder input

Encoder signals (e.g. from an encoder mounted at the stepping motor – for control of the steps - or from a hand wheel with an encoder) and pulse signals (e.g. from a pulse generator) can be connected at a the 9-pole D-Sub-connector 'ENC' or at the inputs I 3 and I 4 at the I/O-Port (25-polige D-Sub-connector – see page 16).

Encoder input at 9-pole D-Sub-connector:

- exists only at versions SERS ... V03 **E50** ... !!!

The 9-pole encoder-connector is located at the SERS-frontpanel (indication 'ENC').

Encoder signals from 2-chanel-encoders (signal A and B and inverted signals /A and /B) with 1:1 duty cycle can be evaluated. The evaluation of the signals includes a 4-times evaluation (every edge of A and B creates an internal pulse), the recognition of the motor direction and analogue and digital signal filters. This connection can be used for a control of steps / load angle, for a hand wheel or for a function 'electrical shaft'.

5VDC encoder

At Pin 2 of the 9-pole D-Sub-connector 'ENC' there is provided a 5VDC voltage (max. 100mA) for the supply of 5VDC-encoders.

24VDC encoder

The SERS does not provide a 24VDC voltage for 24VDC-encoders. The 24 VDC must be supplied externally.

- 24 VDC encoders are allowed to be connected only to types 'SERS ... V03 **E50/24** ...' (SERS-type designation must include '/24' after 'E50') !!!
- 24 VDC encoder may **not** be connected to types 'SERS ... V03 **E50** ...' (SERS-type designation without '/24' after 'E50') !!!

Pin connection	ENC	Pin Belegung
5 : B		9 : /B
4 : shield		8 : GND
3 : n.c.		7 : n.c.
2 : +5VDC		6 : /A
1 : A		

Encoder cable:
When connecting an encoders for the control of step-/load angle then a shielded cable must be used !

Pulse input at I/O-port (25-pole D-Sub-connector) – I 3 and I 4:

At the I/O-Port inputs I 3 and I 4 (Pin 23 / Pin 11) there can be connected encoder or pulse-signals for using a handwheel or realizing an electrical gearing function.

Also a control of step/load angle is possible with these inputs.

For the function "handwheel / electrical gearing function" and control of load angle the signals are evaluated 4-times, and the motor direction is evaluated from encoder signals.

The max. input frequency at the inputs I3 and I4 is 100 KHz

More datas (necessary parameter settings) → see parameter P1029, P1053...

3.5 Status- and error indication via 7-segment display

The 7-segment-display for the WSERS indicates the actual status of the WSERS.

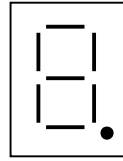

Error and status indications are indicated by constant illuminating characters.

Warnings are indicated by blinking characters.

Indication	description	comment
-	initialisation phase	Is indicated 2 seconds after a power-on-reset
4	ready for switching phase current ON	The motor torque / current is off
5	phase current of motor is ON positioning jobs can be executed	The motor torque is on and there is voltage / current at the motor
5 (blinking)	STOP-switch is open	During an open STOP switch it was tried to move the motor
7	checksum error of dates in E ² Prom	Overwrite E ² Prom-parameters with backed up parameters (with WSERS-software) or select standard parameters (with P1004=3 - see page 70)
8	error over temperature - from 85 °C (± 10%) at the WSERS	check the cooling of the WSERS, ambient temperature to high ?
8 (blinking)	warning over temperature 75 °C (± 10%) at the power amplifier stage	check cooling of SERS – forced draft (fan and 24 VDC in ELK) o.k. ?
9	error under voltage – see 2.1.4	check power supply
9 (blinking)	warning under voltage - see 2.1.4	check power supply
A	Error monitoring stand still function	See parameter P1044 / P1045
A (blinking)	warning position overflow – positioning job is reaching position limit	- parameter W (P47) to big - check positioning mode (for endless positioning → P1014=1 see page 50)
c	Limit switch is open	check limit switches at machine and limit switch inputs WSERS - see 2.2
E	shortcircuit in motor or at power amplifier board	when installing the motor check phase connections
F	error step angle control - the motor could not follow the position command value (only with option step angle control) – see P1029	- check encoder connections - acceleration to high - external load to big (not enough motor torque)
F (blinking)	warning step angle control – description as F – see P1029 page 65	see comment for F
H (blinking)	warning program error – executable program stopped because of an error in the program	check parameters and labels in program (use SERS-software for debugging)
L (blinking)	warning software limit switch	The actual position exceeded the limit position set in P1040 or P1041

Reset an error by writing 'P11=0' (see P11 page 45)

Reset a warning by writing 'P12=0' (see P12 page 45)

3.6 Operating modes - overview

3.6.1 Serial operation

In the serial mode the WSERS stepping motor positioning drives are controlled by a higher ranking master (PC, PLC or NC) via the serial interface RS232C (e.g. COM1 of a IBM-PC) or RS485.

The master controls the connected WSERS-drives by sending commands and parameter assignments as ASCII characters via the serial interface, requests actual parameters like position, drive status, inputs ... , or starts executable programs or subroutines in the WSERS drives.

In standard version there can be controlled up to 127 WSERS-drives from one e.g. PC-COM-interface – 127 different addresses (1 – 127) can be adjusted at a WSERS.

3.6.2 Master mode

In the Master mode one WSERS drive is configured as higher ranking control (Master).

By selecting the address '0' at the DIP-switch, the WSERS will work as Master.

If the Master (with adjusted address '0') is called with the address '200', then it behaves like a slave and can be programmed.

A Master-WSERS sends commands via the serial interface and can control other WSERS-drives in that way. So even complex motion applications can be realised without additional control (PC or PLC).

Characteristics of a WSERS Master:

- all drive functions for a standalone drive
- assigning parameters of other WSERS-drives (e.g. velocity, acceleration, position)
- sending all commands to other WSERS-drives (e.g. start, stop, set output)
- start of executable programs and subroutines of other WSERS-drives
- request of inputs and drive status of other WSERS-drives

3.6.3 Parallel mode

In the parallel mode subroutines (stored in the E²Prom) are called in the WSERS-drives via the digital inputs. The different subroutines are addressed with 6 inputs (binary address 0 to 63). With another input the address is set (strobe) and the addressed subroutine will be started.

The digital (parallel) inputs can be controlled e.g. by manual switches, or by digital outputs of a PLC.

3.6.4 Standalone mode

In the standalone mode the WSERS runs independently without a higher ranking control. The E²Prom program is started by a digital input (start input I8) or automatically, after connecting the WSERS with a power supply (autostart-selection via DIP-switch, see 3.1.5 page 14).

Events at the inputs can control the execution of the program.

4. Programming and operating the WSERS

4.1 Syntax - general notes

- **each line sent to the WSERS must begin with the character '#'** !
e.g.: **#ON** will switch on the phase current – the line begins with '#'
- **each line must be finished with Carriage Return (Return-key** of the keyboard corresponds to the ASCII-character '#13' - decimal number 13 in the ASCII-table - when writing a (e.g.) PC-program) **or Linefeed** (ASCII-character #10)
e.g. programming in PASCAL – a string with an assignment 'W=1000' sent to the WSERS via the COM-interface must be programmed as **string := '#W=1000' + #13**
- Commands will be executed by the WSERS already before receiving a Carriage Return!
E.g. when writing **#ON** and a following **Carriage Return** the current of the motor phases will be switched on already before the Carriage Return !
- There may be **multiple commands and parameters in one line** before writing a Carriage Return – but **maximum 60 characters in one line**.
e.g.: **#ON V=1000 W=2500 O=1 E** may be written in one line and at the line end finished with a **Carriage Return**.
- **Carriage Return (CR - #13) and Line feed (LF - #10) will be echoed with a 'ok' and a digit** by the WSERS, in case the sent commands and parameters are free of errors. The digit can be '0' to '4'.
 - '0' : Drive is running (P336=0)
 - '1' : Drive is in position (P336 = 1)
 - '2' : Drive is running and a warning was created (P12 > 0)
 - '3' : Drive is in position and a warning was created (P12 > 0)
 - '4' : There is an error at the drive (P11 > 0)
 The characters, sent by the WSERS are :
#10 ok1 #10 #13 or #10 ok4 #10 #13 → string with LF, 'ok', digit, LF und CR
 In the programming mode (4.5.3 page 30) there will be sent "pgm" instead of "ok"!
- In the **V24-mode each sent character to the WSERS will be returned** (echoed) from the WSERS (mode-selection via parameter P1017).
Attention : In the mode HANDSHAKE_RS485 the WSERS will return only the "ok" ("pgm") after receiving a Carriage Return or Linefeed - there is no character echo !
- If the **commands or parameters are faulty**, then **error messages** will be returned. Error messages start with the character '*'.
e.g.: *****limit switch open***** in case the drive is on a limit switch (input limit switch is open) and a start command 'E' (execute positioning job) was sent to the WSERS
 When receiving faulty syntax, the WSERS will return immediately an error message.
 When receiving faulty values (e.g. too big) then depending on the values the WSERS will return an error message before or after a Carriage Return.
Attention : In the mode HANDSHAKE_RS485 (see parameter P1017 – Handshake) error messages are returned always only after a finished line (Carriage Return / Line feed) !

- When requesting parameters in the serial mode (e.g. #2P11?) then the WSERS returns the result as follows : 'P11=0' #10 #13 . First the parameter number of the requested parameter (P11), then the character '=', then the content of the parameter (e.g. '0') and at last the line feed character #10 and a Carriage-Return #13 are returned.
- When assigning parameters, there are **no units** allowed
e.g. writing 'V=1000 U/min' is wrong, and an error message will be returned !
Correct : 'V=1000' - the unit is defined in the parameter P44 (scaling for velocity dates)
- **Addressing a WSERS** is realised by sending the drive address via the interface.
e.g.: when sending #2 the drive with the address 2 is called.
After sending an address, all following commands and assignments of parameters are accepted only by the addressed drive. All other connected drives will ignore the commands and assignments.
If some commands or parameter assignments are dedicated for another drive, then first the drives address has to be sent – e.g. #3 .

e.g.: #2 ON The phase current of the drive with address 2 is switched on
 #v=1000 with 'ON', the velocity is set to 1000, the way (distance) to be
 #W=5000 E moved is set to 5000 and with 'E' drive 2 is started.
 #3 ON Afterwards drive 3 is addressed, the current is switched on
 #V=1500 with 'ON', and velocity and the way are set and drive 3 is
 #W=4000 E started.

4.2 Syntax definitions

Following the general syntax definitions for the WSERS.

All expressions and characters, which are not described more detailed must be input directly.

Cursive written expressions are defined more detailed in the following lines.

Expressions in [] are optionally.

All key words may be written in small or big letters.

Explanations to the syntax are behind the comment characters // .

Instruction line

[*drive address*] [*instruction list*] *end of line*

Drive address

decimal constant

// allowed is 0 - 127

*

// addressing all drives – e.g. for synchronically start of all drives – broadcast address

Instruction list

instruction

instruction instruction list

Instruction

"character list"

// Text for displaying in the SERS-Programmer

assignment

command

operator operand

// for arithmetic functions

unary_operator

// for arithmetic functions

IF [!] *address* [*condition decimal constant*] // interrogation see chapter 4.6.1
 WAIT [!] *address* [*condition decimal constant*] // Wait for event
 : [!] *address* [*condition decimal constant*] // manual driving until input is (not) active
 GOTO *decimal constant* // jump to label number *decimal constant*
 GOSUB *decimal constant* // jump to subroutine at label number
 decimal constant
 GT *decimal constant* // equivalent to GOTO
 GS *decimal constant* // equivalent to GOSUB
 RETURN // return from subroutine – target address is the line
 after the last GOSUB command
 RT // equivalent to RETURN
 RS // manual drive right slow (**R**ight **S**low)
 RF // manual drive right fast (**R**ight **F**ast)
 LS // manual drive left slow (**L**eft **S**low)
 LF // manual drive left fast (**L**eft **F**ast)
 L *decimal constant* // label number
 LIST // list program in E²Prom
 LIST . // list actual program line – next line to be executed or
 last listed line
 LIST - // list line before – actual position in program is also set
 to line before
 LIST + // list next line – position in program see LIST-
 LIST *decimal constant* // list line *decimal constant* – program position is set to
 program address *decimal constant* (in ‘PGM’-mode
 LIST0 enables inserting a line at the program begin
 LIST - *decimal constant* // list 20 lines until *decimal constant* – program-
 position is set to address *decimal constant*
 // all LIST-commands will change the actual program
 position !
 LIST *decimal constant*1.*decimal constant*2 // list *decimal constant*2 multiplied 10
 lines from program line *decimal constant*1
 LIST P // list all parameters actual values
 LISTP *decimal constant* // list parameter *decimal constant* (internal order –
 according to P-no. sorted ascending) with actual
 values
 LISTP *decimal constant*1.*decimal constant*2 // list *decimal constant*2 multiplied 10
 parameter from parameter *decimal constant*2 (internal
 order - according to P-no. sorted ascending) with
 actual values
 // // comment character – all characters in a line from here
 will be not interpreted
 PE // end of program
 PSAVE // parameters in the SERS will be stored permanently –
 values from RAM of WSERS into E²Prom of WSERS
 POSSAVE // save P51 (actual-position) into E²Prom
 POS0 // move to electrical “0“-position (every 7,2°)
 POSR // move to position command value (see P1043)
 NEW // equivalent to P0=2 – programming mode with erasing
 of actual program. All characters, sent from now on,
 will be stored in the E²PROM.

PGM // Turning on the programming mode with editing of the actual program. Input lines will be inserted at the actual program position.
 // In the programming mode instructions like LIST, DEL, TR C, will not be stored, but executed !

DEL // erases the actual line in the programming mode
C decimal constant // Changes the value of the assignment at the actual programming position

QUIT // terminates programming mode

RUN // equivalent to P0=1 – start program in E²Prom

TRON // trace mode on – mode for enabling program execution line by line

TROFF // trace mode off

TR? // requests trace mode

TR // enables trace mode and executes of one a program step

VER // shows program version

ON // equivalent to P134=7 – turn on phase current of motor

OFF // equivalent to P134=0 – turn off phase current of motor

condition

>
 <=
 =
 <>

Character list

character
character-list character

Character

// any character except quotation marks “ and 0x00 (=ASCII-character with code 00)

Assignment

address = data
X = operand // accumulator for calculating
address ? // shows parameter data (value - content)
address ?? // shows parameter identification

operator

+ // adding to the accumulator
 - // subtracting from the accumulator
 * // multiplying with accumulator, in case ‘*‘ shall be used at begin of line , then the address of the drive has to be set ahead, for the WSERS not interpreting the character ‘*‘ as broadcast address
 / // dividing accumulator
 & // “AND“ accumulator
 | // “OR“ accumulator
 ^ // “EXCLUSIV OR“ accumulator

unary operator

NOT // inverting accumulator bit by bit
NEG // inverting sign of accumulator

operand

address
 decimal constant

address

A // equivalent to P138 - acceleration
 ADC // equivalent P1046 – analogue Input
 C1, C2, C3 // equivalent P100, P101, P102 - counter
 D // equivalent P1100 – delay time in $\frac{1}{10}$ seconds
 M1, M2, M3 // equivalent P1101, P1102, P1103 – marker
 I1 to I8 // equivalent P1300 – inputs I1 to I8
 I9 to I16 // equivalent P1301 – inputs I9 to I16
 J1 // home switch for requests with IF, WAIT and “:”
 J2 // limit swith left for requests with IF, WAIT and “:”
 J3 // limit swith right for requests with IF, WAIT and “:”
 J4 // STOP-switch for requests with IF, WAIT and “:”
 J5 // service switch for requests with IF, WAIT and “:”
 O1 until O16 // equivalent P1201 until P1216 / output O1 until O16
 P *decimal constant* // parameter - see description of parameters (4.7 page 39)
 POS // equivalent P336 – status In-Position
 V // equivalent P91 - velocity
 W // equivalent P47 – distance to move or position
 WA // as W but additionally P1014=2 (absolute positioning)
 WR // as W but additionally P1014=0 (relative positioning)
 WP // first positioning section in mode polynom positioning
 WAP // as WP but additionally P1014=2 (absolute positioning)
 WRP // as WP but additionally P1014=0 (relative positioning)
 WPT // last positioning section in mode polynom positioning
 WAPT // as WPT but additionally P1014=2 (absolute positioning)
 WRPT // as WPT but additionally P1014=0 (relative positioning)
 X // equivalent P1047 - accumulator for calculating
 Z // equivalent P1 - destination address for master mode

Command

E // start actual positioning job – actual value set in W
 (P47) will be executed
 H // start homing
 S // stop – the motor will be stopped - see also
 parameter P1033 – continue after stop

Data

[-] *decimal constant*

End of line

Carriage Return // RETURN-key of keyboard
 /r // Return character – ASCII-Code 13 (decimal)
 /n // Linefeed character – ASCII-Code 10 (decimal)

Decimal constant

decimal digit
 . decimal digit // e.g. **.5** (= 0.5)
 decimal constant decimal digit // e.g. **10.75**

Decimal digit

0,1,2,3,4,5,6,7,8,9

Separating character

“space character“
 , // comma
 ; // semicolon, prevents a carriage return at
 program input in the actual line
 “tab“ // tabulator character

4.3 Program lines and numbering

Internally each instruction receives its own line number.

The lines **#1 ON V=1000 W=5000 E**
#O1=1 D=10 W=2000 E

are put out in a list (after the instruction : 'list') - with the selected option line numbers (see also parameter P1028) - as follows :

1: **#1 ON V=1000 W=5000 E**
 5: **#O1=1 D=10 W=2000 E**

or (depending on the parameter P1028) :

1: **#1 ON**
 2: **#V=1000**
 3: **#W=5000**
 4: **#E**
 5: **#O1=1**
 6: **#D=10**
 7: **#W=2000**
 8: **#E**

4.4 Limitations for E²Prom-programs

Following limitations for a E²Prom-program apply :

- program memory in standard version : the number of program lines depends on the structure of the program - there are 2Kbyte available, e.g. long lines result in a fewer total number of programmable lines. When programming only one instruction per line, then there can be programmed approximately 300 lines.
- Optionally there is a 8Kbyte version (WSERS with “P8“ in the type designation) with up to approximately 1200 lines respectively instructions
- maximum of 60 characters per line
- maximum of 64 labels – L1 to L64 – (plus Label L65, where the program will jump to after a program stop)
- interlaced storage number for subroutines : max 4 (into each other interlaced program loops)

4.5 WSERS functions and modes

4.5.1 Manual mode - manual drive control (jog)

For the manual drive control (jog) there are 4 different commands :

1. manual drive right slow – RS-function (Right Slow)
2. manual drive right fast – RF-function (Right Fast)
3. manual drive left slow – LS-function (Left Slow)
4. manual drive left fast – LF-function (Left Fast)

Following parameters are available for the manual drive control functions :

Acceleration manual drive control : P1018

Velocity manual drive control slow : P1019

Velocity manual drive control fast : P1020

Enable inputs for manual drive control functions : P1021

The manual drive control functions can be started by

- sending the instructions ‘RS‘ or ‘RF‘ or ‘LS‘ or ‘LF‘ via the serial interface to the WSERS or
- Putting signals at the inputs I1 to I4 at the 25-pole D-Sub-connector (I/O-Port) – see connections page 16.

When using the manual drive control functions via the inputs I1 to I4 the phase current of the motor will be turned on automatically.

When using the manual drive control functions by sending instructions via the serial interface the phase current of the motor must be turned on before (by sending ‘ON‘ to the WSERS).

4.5.2 Executable program mode for master mode, parallel (BCD) mode and standalone mode

Following steps are necessary for a automatically executable program mode for the operating modes master mode, parallel mode and standalone mode:

- writing and downloading an executable program into the E²Prom of the WSERS
- adjusting all necessary parameters in the WSERS
- adjusting the DIP-switches on the WSERS

Executable program

Master mode:

The structure of a master program principally is the same as for programs in other operating modes. Additionally for a master program there are instructions, which are for controlling other WSERS-drives (Slaves). This is done by sending the expression ‘Z=address‘ to the drive to be controlled, where *address* is the drive address of that slave-drive. All following instructions in the program until the next ‘Z=address‘ - expression will be sent to the slave-drive. With the expression ‘Z=0‘ the master assigns the following instructions for himself again (address 0 is the master address). A typical master-parameter, which can be changed only during operation, is P1110 . With this parameter the master decides, weather after starting a positioning job (instruction ‘E‘) it will proceed with the next instruction only after finishing the positioning job or weather it will execute the next instruction without waiting for the end of the positioning job (in that way the master is able to control other drives while it self is still positioning).

See example program page 38.

Parallel (BCD) mode:

A program for the parallel mode consists of one or more subroutines and is programmed as follows : Each subroutine is started with a label (the label number corresponds to the program address) and is terminated with 'RETURN' (or 'RT').

	I1	I2	I3	I4	I5	I6	Jump to Label
#L1	0	0	0	0	0	0	L1
⋮							
#RT	1	0	0	0	0	0	L2
#L2	0	1	0	0	0	0	L3
⋮							
#RT	1	1	0	0	0	0	L4
#L3	0	0	1	0	0	0	L5
⋮							
#RT	1	0	1	0	0	0	L6
⋮							
	until L64						

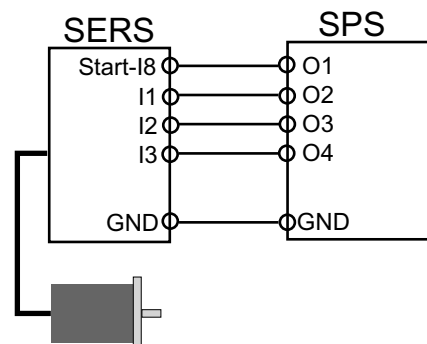

The program waits, until there is a signal edge at the start input (input 8 at I/O-Port). Then, depending on the address, which is created by the inputs I1 to I6 (BCD 0 – 63) the program jumps to the corresponding label (L1 to L64 – see table above) and all instructions until the next RT (RETURN) are executed. After the RETURN the program waits again for the next signal edge at the start input.

Event controlled mode:

In the event controlled mode single subroutines (stored in the E²Prom) are called directly via single inputs.

An executable program consists of one or multiple subroutines which are defined through Label L... and RT.

e.g.: L1 ON RT
L2 V=1000 W=360 E RT

Depending on the activated input the corresponding subroutine will be called: (rising signal edge at input will initiate the jump to the subroutine).

Only the inputs/labels enabled in parameter P1098 are valid for this program mode. The inputs/labels not defined in P1098 may be used for other functions.

P1098 = 1 → jump to L1 at signal edge at input I1
 2 → jump to L2 at signal edge at input I2
 3 → jump to L1 at signal edge at input I1 and jump to L2 at signal edge at I2
 4 → jump to L3 at signal edge at input I3
 5 → jump to L1 at signal edge at input I1 and jump to L3 at signal edge at I3
 ...
 255 → jump to L1 until L8 in case of edges at inputs I1 until I8

A positive signal edge at the input will call the subroutine, if at the time of the signal edge no program is executed (P0=0). If there was a positive signal edge at the input and a program was running at the time, and the input is still active after the program is terminated, then the subroutine will be called after termination of the program.

In case of signal edges at multiple inputs (enabled via P1098) at the same time, then "I1" is the input with the highest priority. "I2" is the input with the next lower priority.. If inputs stay active, then all corresponding subroutines will be called after each other. If an input, which did not lead to the call of its corresponding subroutine yet, changes to inactive state, during another program/subroutine is running, then the subroutine will not be called – meaning the signal edges will not be saved internally.

Standalone mode:

In the standalone mode the E²Prom-program is started with a start signal (autostart via switched on bit 8 of switch 2 – see 3.1.5 page 14 – or start input I8 at I/O-Port) from the program begin. The program execution can depend on events at the inputs (I/O-Port) , or run independently.

Necessary SERS-parameter**Parallel (BCD) mode:**

P1022 Digin-label-enable : The inputs, which are used for the addressing in the parallel mode, have to be enabled in P1022 (see parameter description) and the Start-Input must be set in P1021 (P1021=128)

Event controlled mode:

P1098 enable program jump : the inputs needed for calling the subroutines in the event controlled mode, have to be enabled in P1098.

DIP-switches**General notes:**

Selecting the autostart function at switch 2 (see chapter 3.1.5) – depends on the application

Selecting input signal level at switch 1 (see chapter 3.1.4) – depends on the connected hardware (e.g. control units, to the inputs connected switches are against GND or 24VDC or 5VDC ?)

Switch off service-switch-bit at switch 1 (see page chapter 3.1.3)

4.5.3 Programming mode

When using the SERS-programming software from STOEGRA, you do not need the functions explained as follows !

For entering the programming mode, the SERS must be stopped (no autostart active or a running program must be stopped via the Stop-input or a sent stop command).

There are two different programming modes :

- programming mode with **erasing** of actual program in E²Prom and
- programming mode with **editing** of actual program in E²Prom

The instruction '**NEW**' will start the programming mode with erasing an E²Prom-program, the instruction '**PGM**' will start the programming mode with editing an E²Prom-program.

A short description of the instructions (LIST, DEL, C, QUIT) for the programming mode can be found in chapter 4.2 syntax definitions in the section instructions.

4.5.4 Trace mode

When using the SERS-programming software from STOEGRA, you do not need the functions explained as follows !

In the trace mode an executable program can be executed step by step.

The instructions TRON, TROFF, TR, TR? Are explained in chapter 4.2 syntax definitions in the section instructions.

4.6 Programming instructions

4.6.1 IF : Conditional execution

Syntax : **IF** *event condition digit*

Digit: "0" or "1" respective "0 – 255" in case of programming "IF IN=digit"

The condition depends on the event : "=", ">", "<=" oder "<>"

The former syntax (firmware 100101 and earlier)) using **IF [!] event** still is accepted.

For the old syntax using the character '!' the event will be **inverted**. (**IF !event** means : If the event is not true).

When saving a program with the old syntax into the SERS E²Prom and then reading the program out of the SERS, the program will be listed with the new syntax.

If the event is true, then the next instruction will be executed, otherwise it will be skipped / ignored.

Events may be **parameters** or **digital inputs** (at I/O-Port).

Following conventions are made for the digital inputs:

- **I1 to I8** : if the inputs is set, then the event is true.
e.g.: IF I5=1 If input I5 is set, then execute next instruction,
otherwise skip / ignore next instruction
IF I5=0 If input I5 is not set, then execute next instruction,
otherwise skip / ignore next instruction
- **IN0 to IN255** : IF IN=*digit* requests all inputs, where the values of the inputs are binary coded → (I1=1, I2=2, I3=4, I4=8, I5=16, I6=32, I7=64, I8=128)
e.g.: IF IN5 → If I1 and I3 are set then execute next instruction (5 = I1 + I3)
For negative events use "!" → e.g. IF !IN5 → If not IN5 (I1=0 or I3=0)
- **J1** - Home switch (IF J1=1 → if the drive is on the home switch - opener)
- **J2** - Limit switch left (IF J2=0 → if the drive is on the limit switch left - closer)
- **J3** - Limit switch right
- **J4** - STOP switch
- **J5** - Service switch external

Following parameters may be used as events :

- **P0** - request whether a program is executed (for master mode, if the program execution in the slave has terminated) - possible requests: IF P0=0 or IF P0=1
- **C1 to C3** : counter – each IF-request will decrement the counter by 1
IF C1>1 → (C1=C1-1 and if still C1>1 then execute next instruction)
- **POS (P336)** : IF **POS=1** requests, whether the drive is "In Position", meaning whether it reached the command value position (in master mode for requesting the slave-state).
IF POS=1 (motor is in position) , IF POS=0 (motor is running)
- **P1015, P1016** – request whether drive is in accelerating phase, or in constant running phase (drive runs with constant velocity)
possible requests: IF P1015=1, IF P1016=1, IF P1015=0 or IF P1016=0
- **M1 to M3** (P1101 to P1103) : requests marker
possible requests: IF M1=1 , IF M1=0 , IF M2=1, IF M2=0 , IF M3=1 , IF M3=0
- **P11, P12** : error, warning register : parameter <> 0 → event true
IF P11<>0 requests, whether there is an error (e.g.: temperature error). In case of an error P11 is not zero and the following instruction will be executed.
IF P11=0 executes the next instruction, in case there is no error
IF P12<>0 and IF P12=0 as P11.

- **LP** : IF LP=1 request if P51<P1040 or P51>P1041 → request of status of software-limit switches - possible requests : IF LP=1 and IF LP=0
- **X** : request of accumulator : IF X > 0 or IF X ≤ 0
- **P1123**: request of polynom status: IF P1123=1 → load next polynom section

Example for an IF request:

```
IF P12<>0 O1=1
GT 20
```

If P12 is not equal 0 (a warning is occurred) then output O1 will be set (O1=1 is the next instruction following the IF-request). Afterwards the program will jump to Label 20 (GT20). If P12 is 0 (P12<>0 is wrong), then the next instruction “O1=1“ will not be executed but skipped. The program executes the instruction afterwards (GT 20) and jumps to Label 20.

Following program is identical to above program:

```
IF P12<>0
O1=1
GT20
```

Attention: There is no difference for the SERS weather the instruction following the “IF command“ is in the next program line or in the same line as the “IF command“.

4.6.2 Program labels

Syntax : L *decimal constant* - decimal constant is a value between 1 and 65
e.g. L1 or L64

Labels are used as jump destinations, for creating program loops or subroutines.
Each label number may be defined only once in a program !

In case of P1033=2: The program jumps to Label L65 if the E²PROM-program is terminated suddenly e.g. by a external Stop-command or a drive error (e.g. error temperature). This enables certain actions to be executed in case of an error.

In case the Label L65 does not exist then the program will be terminated after a drive error or a ‘stop‘.

4.6.3 GOTO, GT : jumps

Syntax : GOTO *Label* - Label must be defined anywhere in the program

Alternative syntax : GT *Label*

Program jump to a label (backwards or forwards)

```
#L1
#...
#...
#GOTO 1          // equivalent : #GT 1
#...
```

or

```
#GOTO 1
#...
#...
#L1
#...
```

4.6.4 GOSUB : call of subroutine

Syntax : GOSUB *Label* - Label must be defined anywhere in the program

Alternative Syntax : GS *Label*

Jump to a subroutine

– Each subroutine contains a label at its begin and a 'RETURN' at its end

e.g.:

```
#...
#GOSUB 12        // equivalent : #GS 1
#...
#...
#L12             // start subroutine
#...
#RETURN         // end of subroutine and continue with instruction after last
                'GOSUB'
```

4.6.5 RETURN : terminating subroutine

Syntax : RETURN

Alternative Syntax : RT

The instruction RETURN terminates a subroutine, which was called with 'GOSUB' and initiates a jump to the instruction, which follows the 'GOSUB'.

A RETURN in the parallel mode terminates the called subroutine (called via a signal at the start input and a address at the I/O-Port). Then the WSERS waits for the next subroutine call.

4.6.6 Programming of positioning jobs

A positioning job is specified by the standard parameter

- **acceleration** – Syntax : **A=value**
- **velocity** – syntax : **V=value**
- **way** (relative positioning) / **position** (absolute positioning) – syntax : **W=value**

and executed with the instruction ‘**execute positioning job**’ – Syntax : **E**

For executing a positioning job with the WSERS, only the execute instruction ‘**E**’ has to be sent to the WSERS or ‘**E**’ must be programmed in the executable program in the E²Prom. The parameters A, V and W of a executed positioning job are kept in the memory of the WSERS and if not overwritten they will be used for the next positioning job.

After Power On of the WSERS the parameters A and V stored in the E²Prom are valid. The parameter W after Power ON always is 0 (except W was saved with ‘POSSAVE’) !

The parameter A and V may be redefined any time. If these parameters are overwritten, during the WSERS is executing a positioning job, then they will be valid only for the next positioning job.

Changing W is only possible at standstill of the drive (POS=1), or when the drive runs with constant velocity (constant phase) .

When overwriting W in the constant phase, then in relative positioning mode the new value W will be added to the previous value W and the drive will execute the total new distance W. In absolute positioning mode the drive will position to the new value W. The values W sent during the constant phase may not result in a change of the motor direction. In that case the sent value W will be returned with an error message and only after finishing the actual positioning job, W will be executed with the next instruction ‘**E**’ (start positioning).

Additionally to the standard parameters there are some more parameters, which have influence on the positioning jobs :

- **Positioning mode P1014 (relative or absolute positioning)**
- **Ramp form of the acceleration :**
 - P1032 (exponential or sinus-ramp form)
 - P1005 (acceleration section 1)
 - P1006 (acceleration section 2)
 - P1007 (velocity section 1)
 - P1008 (velocity section 2)
- **Scaling** : P160 (acceleration)
P44 (velocity)
P76 (way/distance – position data)

Alternatively to the assignment W=value there are the commands:

WR=value : positioning mode is set to relative (P1014=0) **and** W=value (e.g. WR=1000)

WA=value : positioning rmode is set to absolute (P1014=2) **and** W=value (e.g. WA=1000)

Following parameters show the actual status of a positioning job:

- **P336** (alternative ‘**POS**’) – POS = 1 if actual position value = position command value
- **P1015 (acceleration phase)** = 1 during accelerating of the drive
- **P1016 (constant phase)** = 1 when the drive runs with constant speed

In the executable program mode the program only continues with the next instruction, when POS=1 is fulfilled. But with parameter P1110 immediately execution of the next instruction independently of 'POS' can be selected (e.g. for the master mode).

4.6.7 Positioning with velocity profiles (polynom positioning)

The drive shall move the distance $W = X1 + X2 + X3 + X4 + X5 + X6$.

First the drive must accelerate with the value $a1$ to the velocity $v1$ and then move with constant velocity $v1$ until the section $W1$ is completed. Then the drive accelerates with $a2$ to velocity $v2$ in the distance section $X2$. The sections $X3$ until $X5$ are as sections $X1$ and $X2$. The last section $X6$ is defined with the acceleration $a6$, the velocity $v6$ and the decelerating ramp B .

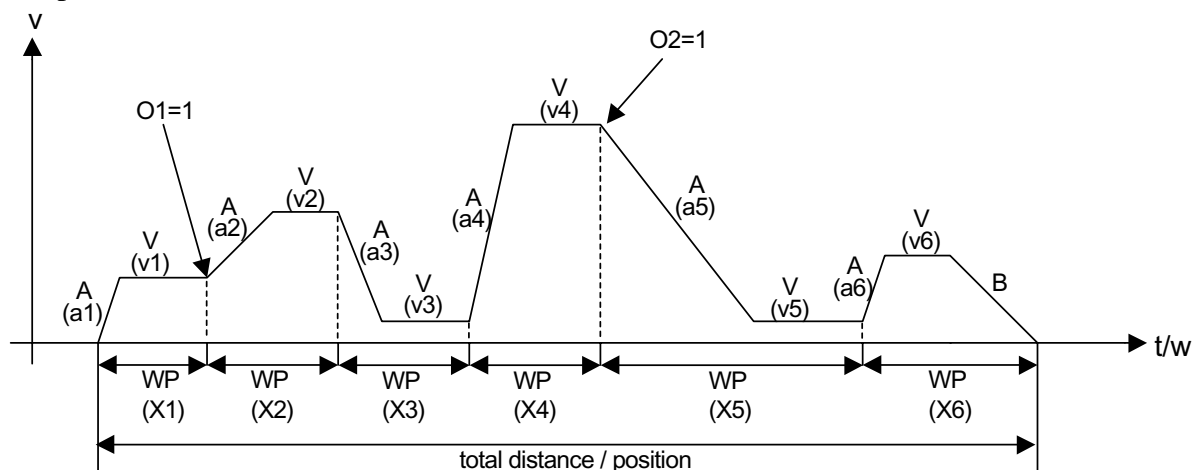

Function principle:

A velocity profile consists of a single or multiple distance sections. Each distance section consists of an accelerating ramp and a section with constant velocity. The last distance section includes additionally the decelerating ramp B . When positioning with velocity profiles a distance section will be defined with the command "WP". The acceleration A and velocity V may be redefined for each distance section or the actual values set may be used (no redefinition of acceleration and/or velocity value in the new distance section).

Within the definition of a distance section first the command "WP" must be defined.

The last distance section must be defined with the command "WPT".

Each distance section must be terminated with "E".

In case WSERS-outputs, marker or any parameters shall be set/defined after terminating a distance section within a velocity profile, (e.g. in the diagram above the outputs $O1$ and $O2$), proceed as follows: at first the next coming distance section has to be defined (during still executing the actual = last defined and started distance section), and after that the parameter, output or/and marker to be set after the still running distance section, may be defined.

Terminating the polynom mode without using "WPT" must be done with by using "POS0" or "POSR" - see parameter P1043. After an error (e.g. because of a wrong definition of polynom sections) the polynom mode stays active, until it will be terminated by a command.

The example / diagram above with 6 distance sections must be programmed as follows:

```

WP=100 A=1000 V=200 E
WP=120 A=300 V=400 E
O1=1
WP=100 A=1000 V=50 E
WP=100 A=1500 V=700 E
WP=200 A=500 V=100 E
O2=1
WPT=130 A=1000 V=50 E

```

The output O1 will be set after terminating the first distance section (but note: the command O1=1 comes only after the definition of the second distance section !).

The output O2 will be set after terminating the fourth distance section (O2=1 is defined after the definition of the fifth distance section !).

The definition of the acceleration within a distance section is optionally. If the acceleration is not defined within the single distance sections, then the last set acceleration

A is used (with exception of the last decelerating ramp → here parameter B is used).

The command “WP” depends on the positioning mode (P1014 – relative or absolute positioning mode) in the same way as the standard positioning command (positioning/distance definition) “W”.

Alternatively to WPT it can be used:

WPA : distance section absolut (e.g. WPA=1000)

WPR : distance section relativ (e.g. WPR=500)

and alternatively to WPT it can be used:

WPTA : terminating distance section absolute (e.g. WPTA=1000)

WPTR : terminating distance section relative (e.g. WPTR=1000)

If the single polynom distance sections are sent via a serial interface (serial mode with RS232 or Profibus-DP or CANopen interface), then the WSERS indicates via parameter P1123 (P1123=1), when the next polynom section must be sent. The WSERS needs to receive the next polynom section definition, before the actual polynom section is terminated by the motor, else there will be created an error message and the motor will be stopped !

4.6.8 WAIT instruction

A "WAIT" instruction stops the execution of an operational program until the defined event comes true.

Possible events are: I1..I16, IN, POS, M1...M3, O1..O16 (the syntax is as the IF - command)

e.g.: WAIT I1=1 waits until input I1 will be set.

WAIT I5=0 waits until input I5 will be erased.

"WAIT" is executed only locally → can not be sent in the master mode to slaves.

4.6.9 “ : “ instruction – jog drive until STOP at an input

Manual driving (jog) with constant velocity until a specified event comes true (then the motor will be decelerated with the jog acceleration value P1018 and then stopped).

e.g. **RS : I1=1** → the motor is driving in jog mode (right slow – with the velocity P1019) until input I1 is set.

Possible commands: RS, LS, RF and LF with the events I1 until I16, IN

If parameter **P1039** <> 0 (a driving distance after stop is defined), the drive will move the relative distance defined in P1039 after the event came true (input is active e.g. at RS:I1=1 or input is deactivated at e.g. RS:I1=0) and then stops. The driving distance after stop (P1039) includes the distance moved during decelerating until motor stop.

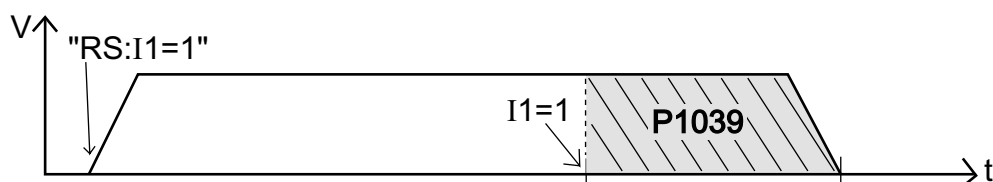

4.6.10 Arithmetical functions in the WSERS

A WSERS-E²PROM program may include arithmetical functions. There are following arithmetical functions :

- a 32-bit accumulator **X** - all arithmetical operations have to be assigned to the accumulator
- six 32-bit variables P1080 until P1085, which may be used for any assignments
- Following arithmetical operations exist
 - Adding '+', Subtracting '-', Multiplying '*', Dividing '/'
 - And '&', Or '|', Exclusive-Or '^'
 - **NEG** : the accumulator's sign will be inverted
- The operations are executed from left to right (no point before line).
- Arithmetical operations always have to be done via the accumulator X !
- There may be used all parameters and 32-bit constants in arithmetical operations.

Examples:

```
X=V*ADC+100 //The actual selected velocity V is multiplied with the value at the
V=X          //analogue input ADC (0 – 100%) and the value 100 is added
```

```
P1081=2
X=V*ADC*3
P1080=X
X=W+10000/P1080*P1081
```

```
X=W
NEG //The accumulator 's sign is inverted (X=-X)
W=X
```

4.6.11 Operation with the SERS-Programmer

When controlling a WSERS with the SERS-Programmer then the parameter section and the program section can be locked via a **Password**.

Only when the operator of the SERS-Programmer knows the Password, then he is able to see and change all parameters and program lines in the WSERS.

Without knowing the password the operator can see and change only **released parameters in the parameter section and released program lines with value assignments** (e.g. V=1000 or P1080=5) **in the program section**. These released parameters and value assignments can be changed by the operator via the SERS-Programmer.

The **Password** is defined in the **parameter P1059**.

The parameters to be released are defined via the **parameter masks** (parameters **P1060 until P1065**) and program lines with value assignments to be released have to be defined via the **program masks** (parameters **P1070 until P1074**).

In the program section there can be displayed any text additionally to the released value assignments. To do that the text to be displayed has to be set between quotation marks (e.g. "diameter"). The text has to be placed between the released Label (releasing of program lines with value assignments is done with the help of Labels - see description under P1070 page 73) and the program line with the value assignment to be displayed.

A detailed description of the operation with the SERS-Programmer can be found in the “manual SERS-Programmer“.

4.6.12 Program examples

Standalone mode:

Following example demonstrates an endless loop. Because all executed positions/ways are always positive (results in running always into the same direction), the positioning mode must be set to RELATIV_ERASE - (the positioning mode ABSOLUT is possible, doesn't make sense in this case, because the program would position 10 times behind each other to the same position '1000').

The **bold printed characters** belong to the program, the *cursive text* behind with the comment characters *'//'* are explanations, which are not part of the program.

```

#ON           // switch motor current on
#V=10         // velocity = 10 (e.g. at rotational scaling : 10 rpm)
#W=25.5 E     // travel distance/position = 25.5 and start ('E') positioning
#L1           // label L1 - destination for program jump with GOTO
#WAIT I2=0   // wait until input I2=0 (wait here as long as I2=1)
#V=1500      // velocity = 1500
#W=2000 E    // travel distance/position = 2000 and start ('E') positioning
#WAIT !IN5   // wait until not (!) IN5 (wait here as long as I1=1 and I3=1 → IN5=1)
#C1=10       // set counter C1=10 - together with IF C1 (below) → loop with 10 runs
#L4           // label L4
#W=100 E     // travel distance/position = 100 and start positioning
#GOSUB 10    // call of subroutine starting at label L10
#IF C1>1    // C1=C1 - 1, if C1 = 0 then execute next instruction
#GOTO 4      // jump to label L4 - loop with 10 runs because of C1=10 and IF C1
#GOTO 1      // program jump to label L1(above)
#L10         // label L10
#O2=1        // set output O2
#WAIT I1=1   // wait until input I1=1
#W=5000 E   // travel distance/position = 5000 and start positioning
#O2=0        // reset output O2
#WAIT I1=0   // wait until input I1=0
#RETURN      // end of subroutine - return to the instruction following last 'GOSUB'

```

Parallel (BCD) mode:

Each subroutine is preceded by a label and finished with a 'RT' or 'RETURN'.

The instructions may be in one line, or in multiple lines behind other.

A label number corresponds to a binary address created by signals at the digital WSERS inputs I1 to I6 (e.g. L1 = address '0', L2 = address '1' or L10 = address '9').

```

#L1 ON RT           // program line for address '0' (no address input is set)
#L2 V=1000 W=2500 E RT // program for address '1' (only I1 is set)
#L3 V=10 W=10.5 E RT // program for address '2' (only I2 is set)
#L4                 // start of program for address '3' (I1 and I2 set)
#V=20.8
#W=40.6
#E
#RETURN             // end of program for address '4'

```

Master mode:

In the following example a master controls two WSERS-slaves with the addresses 1 and 2. The **bold printed characters** belong to the program, the *cursive text* behind with the comment characters *'//'* are explanations, which are not part of the program.

```

#ON           // switch motor current on
#L1           // label L1
#Z=1          // send following instructions/assignments to drive with address 1
#V=1000       // drive 1 : velocity = 1000
#W=500        // drive 1 : travel distance/position = 500
#L2           // label L2
#IF !I3 GT 2 // if input I3 of drive 1 is not active then goto label L2
#E           // drive 1 : start positioning (actual value W of drive 1)
#L3           // label L3
#IF !POS      // if drive 1 is still positioning, then execute next instruction
#GT 3         // jump to label L3
#Z=0          // following instructions will be executed by the master
#V=2000       // velocity = 1000
#W=1000 E     // travel distance /position=1000 and start positioning
#Z=2          // send following instructions/assignment to drive with address 2
#RUN 2        // drive 2 : start subroutine at label L2 (in E2Prom program of drive 2!)
#L10          // label L10
#IF P0        // if program of drive 2 is still running, then execute next instruction
#GT 10        // jump to label L10 (loop waiting for end of program in drive 2)
#Z=0          // following instructions will be executed from the master
#V=10         // velocity=10
#W=20 E       // travel distance /position = 20 and start positioning
#GT 1         // jump to label L1

```

Serial mode:

Bold printed characters between single quotes have to be sent as ASCII-characters via a COM-interface (e.g. COM1 of a PC) to the drive. The Carriage-Return-character is written as '#13' – for the ASCII-Code 13 of the character.

(Note: The SERS returns a 'ok' after each Carriage-Return).

Explanations and instructions printed in cursive style have to be programmed in the used programming language (e.g. PASCAL or C++).

```

' #1' #13       // addressing of the drive – here drive address is '1'
' #ON' #13      // switch on current of motor
' #V=1000' #13  // velocity = 1000 – unit depends on parameter P44
' #W=2500 E' #13 // way to be executed = 2500 – the way really executed depends
                  // on scaling (P76), positioning mode (P1014),
                  // gear ratio and feed constant (P120 – P122)
                  // – 'E' starts the positioning job
' #POS?' #13    // request if POS=1 (P336=1) or POS=0 – moving finished ?
                  // positioning or not ? - the WSERS will return a '1' or '0'
' #P1300?' #13 // request of the digital input port – the SERS returns a value
                  // between '0' and '255'. Set and not set inputs can be filtered
                  // out of the returned value, and depending on the result further
                  // actions can be started.

```

4.7 Parameter overview

Modifying parameters in the WSERS

Parameters are programmed with following syntax : **#Pdata=value**

- the parameter identifier *data* and the new parameter value *value* e.g.: **#P138=1500**

Please note: The drive, where a parameter shall be changed, must be addressed first - meaning the address of the drive has to be sent one time to the drive before sending a parameter assignment to the drive (e.g.: for a drive with the address 1 : **#1P138=1500**).

Followed by a Carriage Return the new value will be accepted by the WSERS and in case of no error the WSERS will return a 'OK'.

If the parameter value is not valid, the WSERS will return an error message.

Reading actual parameters out of the WSERS

A parameter can be read with the instruction : **#Pdata?**

- with the parameter identifier *data* , e.g.: **#P138?**

The WSERS returns the parameter value (in case of parameter values with units like e.g. acceleration the unit will be returned together with the unit)

In the example above e.g. '1500 rad/s2' will be returned.

After sending '**#list p**' to the WSERS, a list of all parameters and values will be returned.

Reading parameter identifications (parameter names) out of the WSERS

A parameter identification can be read by sending the instruction : **#Pdata??**

- with the parameter number *data* , e.g.: **#P138??**

The WSERS returns the parameter identification, e.g.: '**acceleration**'

Liste aller Parameter:

Param. no.	page	Param. no.	page	Param. no.	page	Param. no.	page	Param. no.	page
P0	44	P1 - Z	60	P2	60	P11	45	P12	45
P41	53	P42	54	P44	56	P47 - W	50	P51	51
P76	56	P91 - V	53	P100 - C1	59	P101 - C2	59	P102 - C3	59
P103	51	P108	53	P121	57	P122	57	P123	57
P134	44	P138 - A	54	P147	55	P160	56	P265	69
P336 - POS	49	P403	49	P1001	53	P1002	65	P1003	53
P1004	69	P1005	54	P1006	54	P1007	54	P1008	54
P1009	61	P1010	61	P1011	62	P1012	61	P1013	49
P1014	50	P1015	49	P1016	49	P1017	68	P1018	54
P1019	53	P1020	53	P1021	41	P1022	41	P1023	42
P1024	43	P1025	43	P1026	43	P1027	43	P1028	60
P1029	64	P1030	54	P1031	63	P1032	54	P1033	62
P1034	62	P1035	63	P1036	43	P1037	57	P1038	42
P1039	53	P1040	70	P1041	70	P1042 - LP	49	P1043	52
P1044	68	P1045	68	P1046 - ADC	42	P1047 - X	70	P1050	63
P1051 - WR	50	P1052 - WA	50	P1053	64	P1054	65	P1055	65
P1056	41	P1057	65	P1058	53	P1059	71	P1060-P1068	71
P1070-P1073	73	P1080-P1085	70	R0 - R5	70	P1092	70	P1093	63
P1094	67	P1095	63	P1096	54	P1097	75	P1098	41
P1099	75	P1100 - D	59	P1101 - M1	59	P1102 - M2	59	P1103 - M3	59
P1110	60	P1111-P1116	50	WP - WAPT	50	P1117	69	P1118	62
P1119	68	P1120	68	P1121	49	P1122	69	P1123	49
P1124	65	P1125	43	P1126	43	P1127	69	P1129	49
P1130	42	P1131	43	P1132	43	P1133	44	P1134	44
P1135	42	P1136	44	P1137	46	P1138	52	P1139	52
P1140	52	P1141	59	P1142	75	P1143	67	P1144	67
P1145	67	P1146	67	P1147	67				
P1201-P1204	42	P1205-P1216	42	P1300 / I1-I8	41	P1301 / I9-I16	41		
O1 - O4	42	O5 - O16	42					LS.RS.RS.RF.H	63

	page
4.8 SERS Parameter	
4.8.1 Inputs / Outputs - I/O	
4.8.1.1 Inputs.....	41
4.8.1.2 Outputs.....	42
4.8.2 System parameters	
4.8.2.1 Mode - programming/operation.....	44
4.8.2.2 Power control - drive ON/OFF.....	44
4.8.2.3 Motordrehrichtung Zuordnung.....	44
4.8.2.4 Phasenstrom Chopperfrequenz 12A.....	44
4.8.2.5 Firmware-Version.....	44
4.8.3 Status messages	
4.8.3.1 Drive errors and warnings.....	45
4.8.3.2 Drive status messages.....	49
4.8.4 Operating parameters	
4.8.4.1 Positioning mode.....	50
4.8.4.2 Way-distance / position dates.....	50
4.8.4.3 Velocity dates.....	53
4.8.4.4 Acceleration dates.....	54
4.8.4.5 Homing.....	55
4.8.4.6 Scaling of operating parameters.....	56
4.8.4.7 Mechanics - gear, feeding constant, backlash.....	57
4.8.5 Programming - parameter	
4.8.5.1 Time Delay.....	59
4.8.5.2 Counter.....	59
4.8.5.3 Marker.....	59
4.8.5.4 List option.....	60
4.8.5.5 Special master-mode parameters.....	60
4.8.6 Miscellaneous parameters	
4.8.6.1 Phase current adjustment.....	61
4.8.6.2 Program continue after stop.....	62
4.8.6.3 Manual drive control commands.....	63
4.8.6.4 Manual drive control with timeout.....	63
4.8.6.5 Drive address.....	63
4.8.6.6 Control of load angle.....	64
4.8.6.7 Control of motion.....	68
4.8.6.8 Handshake mode RS232/RS485 interface....	68
4.8.6.9 E ² Prom parameters.....	69
4.8.6.10 Language selection.....	69
4.8.6.11 Software limit switch.....	70
4.8.6.12 Arithmetic parameters.....	70
4.8.6.13 Service switch external.....	70
4.8.6.14 Program-/parameter-mask and password for SERS-Programmer.....	71
4.8.6.15 CANopen Parameter.....	75
4.8.6.16 Profibus Parameter.....	75

4.8 WSERS Parameter

4.8.1 Interface I/O

4.8.1.1 Inputs

Inputs

P1300

P1300 contents the status of the digital Inputs I1 to I8

Set Input : I1 I2 I3 I4 I5 I6 I7 I8
Parameter value: : 1 2 4 8 16 32 64 128

E.g.: in case of P1300 = 11 , then the inputs I1, I2 and I4 are set (1+2+8=11)

I1 - I8 and IN0 - IN255 can be used for IF-requests
see page 30 - chapter 4.6.1 (IF requests)

Inputs I/O-extension

P1301

P1301 contents the status of the digital inputs I9 until I16

→ valid values only in case of installed option “IO“ – SERS with I/O-extension

DigIn-enable

P1021

P1021 specifies, which manual drive function is available at the digital inputs in case of switched off service switch (see page 14 - chapter 3.1.3)

Assignment parameter-value - Inputs - drive-function

Value (dec)	Input	Function
1	I1	Left – slow
2	I2	Right – slow
4	I3	Left – fast
8	I4	Right – fast
16	I5	Start homing
32	I6	Motor ON/OFF , additionally P11=0 and P12=0 at motor → ON
84	I7	Stop
128	I8	Start program

e.g.: #P1021=3 → manual drive slow right and left at the inputs I1 and I2 is always active. (P1021=255 → all functions activated)

Limit switches and Digin

P1056

Parameter P1056 is only for internal use.

DigIn-label-enable

P1022

P1022 specifies, which inputs may be used as address inputs for the parallel-mode.

E.g.: #P1022=15 → inputs I1 - I4 will be used as address-inputs in the parallel mode.

Attention : If a input is enabled also in P021 then it is not available in the parallel mode ! (Attention P1021 must content value 128)

Enable program jump

P1098

Enable program jump in case of a signal at a digital input
→ see chapter 4.5.2 “event controlled mode“

Start-enable**P1023**

0 : Program is started with a positive signal edge at the start input I8
 1 : Program is started , when the start input I8 is set (static signal)

Analogue-Input**P1046**Alternative Syntax : **ADC**

Standard 8-bit resolution with 1bit hysteresis (the value at the input has to change at least 2 LSB, for changing the actual value in P1046 (ADC)

The analogue input is scanned and updated every time when being assigned or used in a formula.

E.g.: $X=ADC$ or $X=V*ADC$ result in reading the analogue input.

ADC-Hysteresis**P1135**

With P1135 a Hysteresis for P1046 (ADC) may be defined.

Standard value is $P1135=7$. This value reduces the resolution of P1046 by 3 bit to totally 7 bit. A signal noise is reduced.

Range of values : 0 – 255 Example:

0 : no Hysteresis and 10 Bit resolution for P1046

7 : Hysteresis with 3 Bit ($7 = 2^3 - 1$) and 7 Bit resolution ($= 10 - 3$) for P1046

255 : Hysteresis with 8 Bit ($255 = 2^8 - 1$) and 2 Bit resolution ($= 10 - 8$) for P1046

x : Hysteresis with n Bit ($x = 2^n - 1$) and m Bit resolution ($= 10 - n$) for P1046

Home switch Digin assignment**P1130**

0 : home switch input = standard home switch

1 to 8 : digital input I1 to I8 = home switch input

Invert limit-/stop switches**P1038**

0 : standard settings

limit switches and stop switch must be connected

24VDC at inputs significates “drive not on switch“ (non-disturbed operation)

1 : test mode – may not be set!

2 : inputs limit- and stop switch inverted

inputs open (24VDC not connected) significates “ drive not on switch“

P1038=2 can be used if limit- and STOP switches do not exist at the machine.

Connecting of these inputs at the WSERS is not necessary then.

4.8.1.2 Outputs**Outputs****P1201**

P1201 - output 1 - alternative syntax O1

until

P1202 - output 2 - alternative syntax O2

P1204

P1203 - output 3 - alternative syntax O3

P1204 - output 4 - alternative syntax O4

#P1201=1 or #O1=1 sets the output O1

#P1201=0 or #O1=0 resets the output O1

Outputs I/O-extension**P1205 (O5)**

Only in case of SERS option “IO“ - I/O-extension:

until

P1205 - output 5 (O5) until P1216 - output 16 (O16)

P1216 (O16)

Break output	P1036
The Ready-signal (usable as signal for activating a break in case of a driver error or motor error or in case of power off e.g. for holding of a z-axis) can be mapped to a digital output by writing	
1..4 : switching on output O1..O4 in case of an error	
-1..-4 : switching off output O1..O4 in case of an error	
0 : function is disabled	
Compare position 1	P1024
If the position, defined in parameter P1024, is reached , then the output or marker, defined in P1025, will be set or reset see P1025	
Compare output 1	P1025
When actual-position (P51) = P1024 and P1025=	
0 → no action	
1 to 4 → corresponding output will be set (e.g.: P1025=3 → O3 will be set)	
-1 to -4 → corresponding output will be reset	
5 to 7 → marker 1 to 3 will be set (5 = marker 1 , 6 = marker 2 , 7 = marker 3)	
-5 to -7 → marker 1 to 3 will be reset (e.g.: P1025=-6 → marker 2 will be reset)	
Compare position 2	P1026
see P1024	
Compare output 2	P1027
See P1025	
Output “Motor IN-Position” (P336)	P1125
P1125 may be configured as follows:	
1..4 : output O1..O4 =1 if P336=1 (SERS IN-Position) , O1..O4 =0 if P336=0	
-1..-4 : O1..O4 =0 if P336=1 (SERS IN-Position) , O1..O4 =1 if P336=0	
0 : function disabled	
→ e.g.: P1125=2 → when motor is running (P336=0), then O2=0, at standstill → O2=1	
Output “program active” (P0)	P1126
P1126 may be configured as follows:	
1..4 : output O1..O4 =1 if P0=RUN (program is running) , O1..O4=0 if P0=0	
-1..-4 : O1..O4 =0 if P0=RUN (program is running) , O1..O4=1 if P0=0	
0 : the function is disabled	
→ e.g: P1126=1 → if a program is running (P0=RUN), then O1=1, else → O1=0	
Output WSERS error (P11)	P1131
0 : function disabled	
1..4 : output O1..O4 =1 if P11<>0 (error active) and O1..O4=0 if P11=0	
-1..-4 : O1..O4 =0 if P11<>0 (error active) and O1..O4=1 if P11=0	
Output WSERS warning (P12)	P1132
0 : function disabled	
1..4 : output O1..O4 =1 if P12<>0 (warning active) and O1..O4=0 if P12=0	
-1..-4 : O1..O4 =0 if P12<>0 (warning active) and O1..O4=1 if P12=0	

4.8.2 System parameters

4.8.2.1 Mode programming/operation

E²PROM Modus

P0

- 0 : The E²Prom - program is waiting for an action (e.g. a command via the serial interface or a start command)
If the programming mode is active, then it will be terminated with P0=0
(alternative syntax : **quit**)
- 1 : the assignment P0=1 starts the E²Prom-program during operation (E²Prom-program is running), parameter P0 = 1
(alternative syntax : **run**)
- 2 : P0=2 starts the programming mode - the actual E²Prom-program will be erased all following instructions (except 'list', 'quit', 'pgm', 'trace') will be stored into the E²Prom After each Carriage Return the SERS returns a 'pgm'
(alternative syntax : **new**)
The instruction **pgm** also enters the programming mode, but the actual E²Prom-program will not be erased, but can be edited.

4.8.2.2 Power control - drive ON/OFF

Master-control word

P134

- 0 : Switch motor phase current off (alternative syntax : **OFF**)
7 : Switch motor phase current on (alternative Syntax : **ON**)

4.8.2.3 Motor direction assignment

Direction turn

P1134

This parameter is for assigning the movement commands (e.g. „RS“ or „LS“) and the position to the physical motor direction. Changing the parameter P1134 has the same result as exchanging the motor connections within one motor phase (the motor then turns physically into the opposite direction).

- 0** : standard motor direction
1 : motor direction inverted

4.8.2.4 Phasen current chopper frequency at 12A version

Increased chopper frequency

P1136

At all SERS versions until 6A the chopper frequency is approx. 18KHz.

At SERS versions with 12A the chopper frequency is set to 12KHz (standard for 12A).

Standard setting is P1136=0.

With P1136=1 for the 12A versions the chopper frequency can be increased to 18KHz.

It is not recommended to change the setting of P1136 and keep the chopper frequency at 12KHz for 12A versions. A higher chopper frequency will result in increasing losses and to increasing temperatures at the SERS control.

At versions until 6A parameter P1136 cannot be changed.

4.8.2.5 Firmware version

Firmware version

P1133

The command "VER" also returns the value of P1133 – read only parameter

4.8.3 Status messages

4.8.3.1 Drive error and warnings

Drive error

P11

In case of an error in the SERS, parameter P11 contents the corresponding errors (each error will set a certain bit in P11).

A drive error always results in decelerating of the drive (with the value defined in parameter P1030). When the motor stopped, the motor phase current will be switched off and afterwards the ready signal will be reset (see page 9 - relay will open). Via parameter P1036 there may be defined that an output (O1-O4) will be set in case of an error.

Reset of drive error messages

After an error occurred, the motor phase current may be switched on and the drive can be moved only if there is no error anymore and the error message was reset with the instruction **P11=0**.

In case of an error 'short circuit power amplifier or motor' (P11=128) before writing 'P11=0' the STOP input (see chapter 2.2) of the WSERS must be opened and then closed again.

Assignment error number - drive error:

- 2 : error over temperature - the heat sink temperature is over 85 °C (+/- 10°C)
- 32 : error control of load angle – see P1029 (only with installed option control of load angle)
- 128 : short circuit at amplifier board or motor
- 512 : error undervoltage - the power supply is too low (see page 10)
- 2048 : error motion control (see P1044)
- 8192 : error position limit control - drive is on limit switch (input limit switch is open)

A value 514 has the significance : error over temperature (2) and undervoltage (512) occurred.

Drive warnings

P12

If a warning occurs, it will be indicated in P12. After the reason for the warning disappeared, P12 still contains the warning (reset P12 with the assignment P12=0). (except values 2 and 4 – these warnings are reset automatically, when the reason for the warning disappeared)

Assignment parameter values - drive warnings:

- 1 : Warning limit position – P51 < P1040 or P51 > P1041 - software limit switch reached.
- 2 : Warning over temperature - the heat sink temperature exceeds 75 °C (+/- 10°C)
- 4 : Warning under voltage - the voltage supply is too low (see page 10)
- 8 : Internal position limit - the internally calculated position value can not be imaged to the scaled value.
- 16 : An error message was generated - e.g. "parameter value too big" (after trying to assign a parameter with a not valid - too big - value), or "destination does not exist", when trying to jump to a not existing label in an executable program in the E²Prom
- 32 : Error control of load angle – see P1029 (only with installed option control of load angle)
- 64 : Position limit command value - the set position command value is too big
- 128 : Program error – the operational program was ended due to an error in the program
- 1024 : RS232 buffer overflow (too many RS232 characters received within short time)

Last error/warning message number (errno)

P1137

The last error message (also indicated by P12 =16) is saved into P1137 as error number (errno - assignment "errno" to error message)

List of all error numbers (errno)

- 1 : to big
- 2 : to small
- 3 : not valid
- 4 : invalid output
- 5 : EEPROM storage full
- 6 : EEPROM acknowledge timeout
- 7 : EEPROM no acknowledge
- 8 : EEPROM no page begin
- 9 : run decimal constant to small
- 10 : decimal constant to big
- 11 : unknown if event
- 12 : admission refused
- 13 : Parameter not existing
- 14 : adc expected
- 15 : end of text expected
- 16 : input text only in pgm mode
- 17 : text to long
- 18 : [decimal constant pgm psave] expected
- 19 : * permitted only at P1 or z
- 20 : data or z expected
- 21 : command expected
- 22 : programming mode not active
- 23 : if expected
- 24 : if event expected
- 25 : goto or gosub or GT or GS expected
- 26 : goto or gosub expected
- 27 : goto expected
- 28 : goto decimal constant expected
- 29 : gosub expected
- 30 : gosub decimal constant expected
- 31 : [return RT run rs rf] expected
- 32 : return expected
- 33 : [decimal constant list ls lf] expected
- 34 : = or ? expected
- 35 : [decimal constant on off] expected
- 36 : decimal constant or n expected
- 37 : decimal constant expected
- 38 : run expected
- 39 : [new, neg, not] expected
- 40 : new or neg expected
- 41 : list expected
- 42 : quit expected
- 43 : off expected
- 44 : program still running
- 45 : pgm expected
- 46 : Programming mode not active
- 47 : del expected
- 48 : data expected

49	: change: only constant allowed
50	: decimal constant or pos expected
51	: pos expected
52	: psave expected
53	: [tr tron troff] expected
54	: program not running
55	: troff expected
56	: ver expected
57	: 1, 2, 3 or 4 expected
58	: pos or possave expected
59	: lp expected
60	: possave expected
61	: data or parameter expected
62	: semicolon not allowed
63	: not expected
64	: not known status
65	: program start not possible when service switch is ON
66	: programmstart not possible, error P11
67	: stop switch is active
68	: stop switch is open
69	: not valid program existing
70	: drive must stand still
71	: unknown destination
72	: destination not valid
73	: Stack overflow
74	: unknown Opcode, forgot return ?
75	: unknown fxxx Opcode
76	: invalid Opcode for destination address
77	: unknown f7xx Opcode
78	: limit switch open
79	: drive not enabled (OFF)
80	: unknown positioning mode
81	: drive must run constant or stand still
82	: invalid EEPROM mode value
83	: label already defined: L
84	: position difference to big
85	: new position to big
86	: new position to small
87	: new residual position to short
88	: compare position 1 is to big
89	: compare Position 1 is to small
90	: compare Position 2 is to big
91	: compare Position 2 is to small
92	: new modulo value is to big
93	: not writable, during drive is positioning
94	: solder bridge is set wrong for this range
95	: negative software limit position is bigger than positive position
96	: exponent to big
97	: exponent to small
98	: calculation result is to big

- 99 : calculation result is too small
- 100 : calculation result is too big to be displayed
- 101 : calculation result is too small to be displayed
- 102 : division through 0
- 103 : bus stopbit is active
- 104 : subindex not existing
- 105 : value can not be written (read only parameter)
- 106 : value can not be read
- 107 : Polynom with backlash not allowed
- 108 : Missing Polynom data for next section
- 109 : Wait expected
- 110 : ≤ 0 expected
- 111 : $= 0$ expected
- 112 : 0 expected
- 113 : 0 or 1 expected
- 114 : $>$ expected
- 115 : 1 expected
- 116 : $=$ expected
- 117 : 3 expected
- 118 : Polynom end too short for deceleration (false definition of polynom section)
- 119 : A too small
- 120 : A too big
- 121 : V too small
- 122 : V too big
- 123 : Polynom data reload not possible
- 124 : RS232 buffer overflow
- 125 : load angle error

4.8.3.2 Drive Status messages

Position status - In_Position P336 (POS)

Alternative syntax : POS

While the drive is running → P336 = 0 else → P336 = 1

Independently messaging In_Position P1121

0 : disabled

1 : after terminating a positioning job the string "@nPOS=1" will be sent, where n is the drive address (e.g. SERS with address 2 → message "@2POS=1")

Independently messaging Program_Finished P1129

0 : disabled

1 : after finishing an operational program "@nP0=0" is sent, where n is the drive address (e.g. a SERS with address 2 → message "@2P=0")

Position feedback value status P403

If the position feedback value is valid (after Power-On of the SERS there was at least once a successful homing procedure), then → P403 = 0
After a Power-On (and still no successful homing procedure) → P403 = 3

Accelerating phase P1015

While the drive is accelerating → P1015=1

Constant phase P1016

While the drive is running with constant velocity → P1016=1

Drive status and limit switch P1013

word (2 byte) – only read parameter

Consists of the driver status and the status of the limit switch inputs

Set (active) bit :

0 (decimal value 1) : limit switch right open (drive error) – syntax for IF : J3

1 (decimal value 2) : limit switch left open (drive error) – syntax for IF : J2

2 (decimal value 4) : STOP-switch open (drive stops) – syntax for IF : J4

3 (decimal value 8) : home switch open – syntax for IF : J1

7 (decimal value 128) : service-switch open (inactive) : syntax for IF : J5

All other bits are used internally.

For checking e.g. the limit switch left:

AND-function of P1013 and the decimal value of the bit to be checked

→ P1013 & 2 = "2", if the bit is active, else the result of the AND-function is "0"

Alternatively request directly via "Jx" : IF J2=1 (see also page 30 "IF-requests")

Limit position exceeded P1042 (LP)

Alternative syntax: LP - see also description P1040/P1041 page 65

If P51 < P1040 or P51 > P1041 then P1042=1 else P1042=0

Load next polynom section P1123

The SERS expects the definition of the next polynom section, when P1123=1.

Necessary for polynom driving in the serial mode → see chapter 4.6.7 (polynom driving)

4.8.4 Operating parameter

4.8.4.1 Positioning mode

Positioning mode

P1014

- 0 : RELATIVE - the new position command value is the actual position command value plus the value stored in W (P47). The drive is running the distance stored in W (P47) after receiving the instruction 'E'.
- 1 : RELATIVE ERASE - After receiving the instruction ('E') the drive is running the distance stored in W (P47) and P51 (actual position) is set to zero before starting. This mode is used for endless positioning. **Also pay attention to P103.**
- 2 : ABSOLUTE - An instruction 'E' starts positioning to the absolute position stored in W (P47).
After finishing positioning the position value (P51) = W (P47) !
- 3 : RELATIVE_WITH_OVERFLOW_COUNTER
The 16 Bit counter P100 (C1) is used as overflow counter.
The position with overflow is: $X=C1 * P103 + P51$
So the max. relative position is $\pm 5.8982 * 10^9$ Grad (rotational)
respectively $\pm 4.7186 * 10^9$ mm (linear).
→ but the max. value for a single positioning job is the max. value of P103
(via the polynom driving mode there may be positioned larger distances).

4.8.4.2 Way/distance/position dates

Position command value

P47 (W)

Alternative syntax : **W**

The really executed motor movement depends on the positioning mode (P1014), on the scaling of the position dates (P76) and on the parameters P121 - P123.

The value ranges are in case of 1:1 gear ratio and feeding constant = 1 (P121=P122=P123=1)

Value range : Rotational : -214748.3647 to 214748.3647 (°)
Linear : -167772.1599 to 167772.1599 (mm)
Incremental : --2147483639 to 2147483639 (increments/steps)

Starting a positioning procedure is done by the command 'E' - e.g. '#W=360 E'

New relative position (position command value - relative)

P1051 (WR)

Alternative syntax : **WR**

Description as **W** (P47) but additionally the positioning mode is set to RELATIVE (P1014=0)

New absolute position (position command value - absolute)

P1052 (WA)

Alternative syntax : **WA**

Description as **W** (P47) but additionally the positioning mode is set to ABSOLUTE (P1014=2)

Position command value Polynom

P1111 (WP)

Alternative syntax : **WP**

Description as "W" (P47), but definition of distance section at polynom driving (see chapter 4.6.7)

Position command value relative Polynom**P1112 (WRP)**Alternative syntax : **WRP**Description as “**WR**“, but definition of distance section at polynom driving (see chapter 4.6.7)**Position command value absolute Polynom****P1113 (WAP)**Alternative syntax : **WAP**Description as “**WA**“, but definition of distance section at polynom driving (see chapter 4.6.7)**Position command value Polynom termination****P1114 (WPT)**Alternative syntax : **WPT**Description as “**W**“, but definition of last distance section at polynom driving (see chapter 4.6.7)**Position command value relative Polynom termination****P1115 (WRPT)**Alternative syntax : **WRPT**Description as “**WR**“, but definition of last distance section at polynom driving (see chapter 4.6.7)**Position command value absolute Polynom termination****P1116 (WAPT)**Alternative syntax : **WAPT**Description as “**WA**“, but definition of last distance section at polynom driving (see chapter 4.6.7)**Position value****P51**

Stores the actual position of the drive.

P51 may be assigned with any value (e.g. for setting a zero-position).

After Power-On of the SERS P51 is set to the value ‘0’, because P51 is not saved automatically into the E²Prom of the SERS.With the command **POSSAVE** the actual value in P51 can be saved into the E²Prom.

After the next Power-On of the SERS, P51 is set to this saved value.

Modulo value for position command value**P103**

Important parameter for an "endless"-operation at positioning mode RELATIV ERASE.

P103 must be bigger than the biggest single distance to be executed !Also **P103 must be an endless to be scaled value**, that means P103 must be able to be executed without a rest distance (corresponding to the physically resolution of the drive of 12800 Increments/revolution).

Suitable values at a gear ratio of 1:1 and a feeding constant =1 are e.g. 360 and multiples of 360 at rotational scaling, 12800 and multiples of 12800 at incremental scaling, or 1 and multiples of 1 at linear scaling.

Different gear ratios and feeding constants must be taken into account,

e.g.: linear scaling, gear ratio 2:1 and feeding constant = 5

→ 2 motor revolutions are 5 mm → 1 rev = 2,5 mm

→ because 1 motor revolution always can be executed without rest and 2.5 mm = 1 rev.

→ suitable values for P103 : Multiples of 2.5mm e.g. 2500 mm (selected value must be greater than the greatest to be executed single distance !)

Erase phase position / position correction**P1043**

0 : no function

1 : alternative syntax: **POS0**

When the actual position was stored with the command **POSSAVE** and the real physical position of the drive was changed, e.g. after switching the drive off (what results in switching off the phase current, and because of that losing the torque), then the phase zero-position can be reset to its origin only with command POS0 (equal to P1043=1).

At the phase-zero-position the current in phase 1 of the stepping motor is set to positive 100% and the current in phase 2 is set to 0%. If the POSSAVE-command is never used, then after Power-On of the SERS the motor is always set to a phase-zero-position and P51=0°.

With 'POS0' the drive first runs from the actual set phase-position (e.g. after a POSSAVE-command P51=361,8°) to the next phase-zero-position - to 360° in the example - and afterwards P51 is set to 0° (P51=0°).

POS0 also does a reset of the polynom mode (started by a WP command).

2 : alternative Syntax : **POSR**

Motor is moved into position command value P47 with homing velocity P41 – command can be used only after an error P11=32 or a warning P12=32 (presupposition is a motor with encoder, SERS with option E50, P1029=1 or P1029=2, and P1053=8).

After the motor stopped because of e.g. a mechanical overload (and the max. load angle was exceeded) the real motor position is detected by the encoder signals. The difference between motor position and position command value will be corrected by the command **POSR**. POSR also does a reset of the polynom mode (started by a WP command).

3 : Command P1043=3 will execute POSR also without an existing error P11=32 or a warning P12=32.

POSR tries**P1138**

0 : function disabled (standard setting)

n : in case of a load angle error (see description for P1043=2 - POSR) the WSERS tries max. "n-times" to execute command POSR for correcting the error.

If a POSR try does not succeed (there is again a load angle error) then the SERS will try the correction (POSR) max. "n-times" again. The "POS-signal" (see P336) stays active (POS=0) as long as the load angle error - correction tries last.

Range of values for P1138: 0 to 65536

POSR Delay time**P1139**

Delay time between a load angle error and automatical correction if P1138 <> 0

The value 1.0 corresponds to 0,1s (100ms), the value 10.0 corresponds to 1s, ...

Range of values for P1139 : 0 to 327.6 (max. 32,76 seconds)

Adjustable in steps of 0.1 (corresponds to steps of 10ms), standard setting : P1139 = 1.0

POSR mode**P1140**

Bit 0 (decimal 1) : Bit 0 = 1: if P1138 <> 0 and the motor is moved out of its position at stand still, then an automatical correction (POSR) is executed

Bit 0 = 0: (standard setting) if P1138 <> 0 and at motor stand still no automatical correction with POSR will be executed after a load angle error

Bit 1 (decimal 2) : Bit 1 = 1: after each successful POSR again P1138 new correction tries are available for any other load angle error later

Bit 1 = 0 : only P1138 tries all together are available (counted from Power-ON)

Leave Zero Phase**P1001**

P1001=0 : normal operation

P1001=1 : Phase positions, where one of the phases carries a very low current, are left.

When reaching a position, which is multiple of $1,8^\circ$ or is within $0,1^\circ$ after or before (e.g. 0° , $1,74^\circ$, $1,8^\circ$, $1,85^\circ$, $3,57^\circ$, $3,6^\circ$, $3,69^\circ$...), the drive moves on or returns until reaching a position which is $0,1^\circ$ after or before a multiple of $1,8^\circ$ (e.g. position command value is $3,6^\circ \rightarrow$ motor moves until $3,7^\circ$ or position command value is $5,35^\circ \rightarrow$ motor moves until $5,3^\circ$)

This is for evitating a possible noise of the chopper at the motor at motor stand still.

P1001=2 : move 0.2 degree away from zero phase

P1001=3 : move 0.3 degree away from zero phase

Distance after stop**P1039**The distance after Stop is activated in case it is not Zero (P1039 \neq 0).

Scaled value (according to P76)

Relative distance into the same direction with identical velocity and jog acceleration. The value P1039 is the relative distance executed after the Stop event of a “ : “ - command.

e.g.: RS:I1=1 (see chapter 4.6.9).

A set backlash (P1037 \neq 0) will be ignored in case of a set P1039 (P1039 \neq 0).

During executing the distance P1039 the parameter P108 (Feedrate Override) is ignored.

Save position in case of under voltage**P1058**

P1058=0 : no function

P1058=1 : If the supply voltage is lower then a minimum value - U_B (see page 10) -

(\rightarrow error under voltage in P11) then the command **POSSAVE** (see P51) is executed. Presupposition is, that the supply voltage falls down slowly (sufficient big electrolytical capacitors in the AC/DC power supply)
>10ms between U_B and U_L (see page 10)

4.8.4.3 Velocity dates

All velocity values depend on the scaling P44

Velocity - Positioning**P91 (V)**

Alternative syntax : V

Maximum selectable value at rotational scaling (U/min) : 10000

Velocity manual slow**P1019****Velocity manual fast****P1020****Velocity homing****P41**

Velocity after start homing, if the homing switch input is not set.

Velocity homing slow**P1003**

Velocity during homing, when the homing switch input is set.

Also used for velocity for backlash-function (see P1037)

Feedrate override**P108**

Possible values : 0 - 100 (unit is %)

The homing velocity P41 and the jog velocities P1019 and P1020 will be multiplied with this value.

4.8.4.4 Acceleration dates

All accelerating values depend on the scaling (P160)

Acceleration - positioning

P138

Alternative syntax : **A**

Maximum selectable value at rotational scaling : 100000 rad/s²

Acceleration - manual drive

P1018

Acceleration - homing

P42

Acceleration at drive error

P1030

When an error occurs (see P11) or the Stop input is set, then the drive will decelerate with the value defined in P1030.

The value must be as great as possible, but only as great as the stepping motor will not lose its synchronous running at worst conditions.

Ramp form of acceleration

P1032

0 : exponential

1 : sinus

(see drawing below)

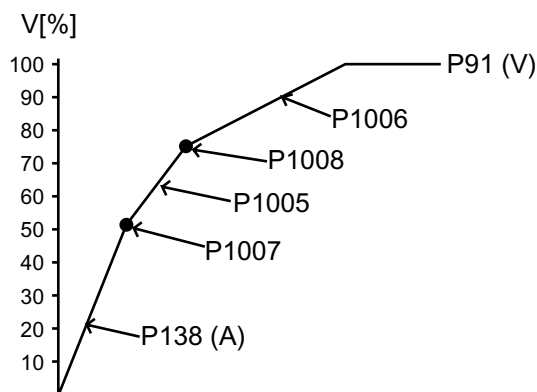

Exponential acceleration

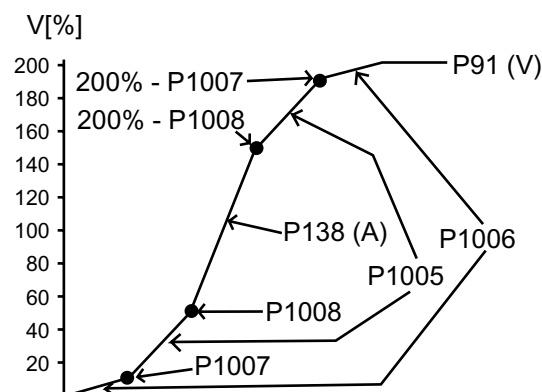

Sinus Acceleration

Acceleration section 1

P1005

Indication in % of P138 (A) , value range : 0 to 100

Velocity section 1

P1007

Indication in % of P91 (V) , value range : 0 to 100

Acceleration section 2

P1006

Indication in % of P138 (A) , value range : 0 to 100

Velocity section 2

P1008

Indication in % of P91 (V) , value range : 0 to 100

Ramp down / Deceleration at end of polynom

P1096 (B)

Alternative syntax : **B**

Max. adjustable value in case of rotational scaling : 100000 rad/s²

4.8.4.5 Homing parameter

Start Homing

When receiving the command **H** or in case of an active signal at the digital input I5 (depends on P1021 and the service switch) the drive starts running to the home switch. The drive accelerates with the "acceleration-homing" (P42) to the velocity "velocity-homing" (P41). At a positive edge of the home switch the drive decelerates until motor stop. Then the drive runs with the "velocity-homing slow" (P3) into the opposite direction, until reaching the negative edge of the home switch.

In case of start homing when the drive is on the reference switch, then the drive runs with "velocity homing slow" until reaching a negative edge of the home switch.

The homing direction is defined in P147.

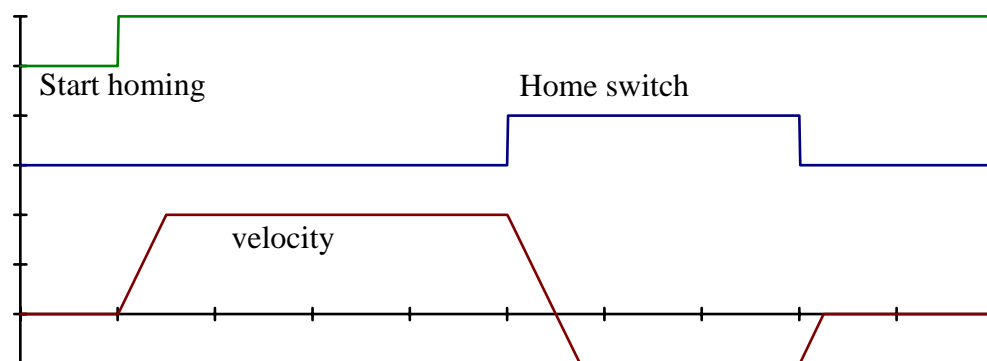

Homing parameter

P147

Bit 0 (1 decimal) : Homing - direction :

0 = positive

1 = negative

Bit 1 (2 decimal) : Homing mode :

0 = homing to homing switch

1 = homing to limit switch

→ limit switch will be used as homing switch only during homing procedure

Bit 2 (4 decimal) : Reset position :

0 = homing to switch only

1 = homing to switch and afterwards moving on to the next electr. reset-position
(every 7,2° at motor - in case of 1,8° stepping motor)

Bit 3 (8 decimal) : Controlling software limit switch :

0 = ignore P1040 und P1041 when homing

1 = do not ignore P1040 und P1041 when homing

Bit 4: (16 decimal) Home input inverted :

0 = not inverted (standard), input closer

1 = inverted, input opener (no signal at input = drive is on the home switch)

Bit 5: (32 decimal) Option homing to switch middle position :

0 = function disabled

1 = homing to switch middle position (the drive first travels to the right and left edge of the switch, and in that way measures the switch, then it travels to the middle of the switch)

Bit 6: (64 decimal) Use Zero-pulse instead of homing switch :

0 = homing to homing switch (or limit switch – depending on Bit 1)

1 = homing to zero pulse (for encoders with zero pulse channel)

Bit 7: (128 decimal) After homing, move motor to zero pulse and afterwards to reset-position:

0 = Standard homing procedure (depending on Bit 1 to Bit 6)

1 = first homing to home switch, then travel to zero pulse and then travel to next reset position (as Bit 2 = 1)

4.8.4.6 Scaling of operating parameters

Following scaling modes are possible :

Incremental - unit [increments] - 12800 increments = 1 motor revolution

Linear - unit [mm] - 1mm = 1 motor revolution

Rotational - unit [°] - 360° = 1 motor revolution

In case of the scaling modes rotational and incremental the reference may be the load or the motor shaft. In case of a reference load the parameters P121 and P122 (gear ratio) will be taken into account when calculating the operating datas.

In case of the scaling mode linear the parameters P121, P122 and P123 (feeding-constant) will be taken into account always when calculating the operating datas!

Most of the scaled values include decimal places. The number of decimal places varies - e.g. in case of linear position datas → 4 decimal places.

The value 120mm is stored as 120.0000 mm. When writing values in ASCII-format (WSERS with RS232-interface) only the value '120' must be written.

In case of option Profibus-interface (WSERS.. PB-DP and binary mode) or CANopen (WSERS ... CAN) the value '1200000' must be written for '120' mm (includes the 4 decimal places)

Scaling position dates

P76

Bit	76543210	decimal	unit	scaling mode	reference	decimal places
00000000		0	incr	Incremental	Motor	0
01000000		64	incr	Incremental	Load	0
00000010		2	°	Rotational	Motor	4
01000010		66	°	Rotational	Load	4
00000001		1	mm	Linear	Load	4
00010001		17	in	Linear	Load	6

Pre-selected is 2 (° – rotational motor)

Scaling Velocity dates

P44

Bit	76543210	decimal	unit	scaling mode	reference	decimal places
00000000		0	U/min	Incremental	Motor	4
01000000		64	U/min	Incremental	Load	4
00000010		2	U/min	Rotational	Motor	4
01000010		66	U/min	Rotational	Load	4
00000001		1	mm/min	Linear	Load	3
00010001		17	in/min	Linear	Load	5

Pre-selected is 2 (U/min – rotational motor)

Scaling Acceleration dates

P160

Bit	76543210	decimal	unit	scaling mode	reference	decimal places
00000000		0	rad/s ²	Incremental	Motor	3
01000000		64	rad/s ²	Incremental	Load	3
00000010		2	rad/s ²	Rotational	Motor	3
01000010		66	rad/s ²	Rotational	Load	3
00000001		1	mm/ s ²	Linear	Load	3
00010001		17	in/ s ²	Linear	Load	5

Pre-selected is 2 (rad/s² – rotational motor)

4.8.4.7 Mechanics - gear ratio, feeding constant

Feeding constant

P123

The unit depends on P44 (scaling position dates)

The feeding constant transforms a rotational movement into a linear movement (e.g. spindle)

The feeding constant is equivalent to the made linear distance at one revolution (of the spindle).

Pre-selected value: 1

Example.: Spindle with lead of 5 (=5mm per revolution) → P123 = 5

Gear ratio:

Gear - input revolutions

P121

Input revolutions at the first stage of all gears between the motor shaft and the load

- seen at the motor shaft

Pre-selected value: 1

Gear - output revolutions

P122

Output revolutions at the last stage of all gears between the motor shaft and the load

- seen at the load

Pre-selected value: 1

$$\text{Gear ratio} = \frac{\text{Gear input revolutions}}{\text{Gear output revolutions}}$$

Example.: gear 8:1 → P121=8 and P122=1

Backlash

P1037

Backlash correction - a spindle or a chain includes a backlash. By writing the backlash value (value depends on scaling for position dates P76 - e.g. 0,1° in case of rotational scaling) into parameter P1037, the backlash when reversing direction or rebounding after positioning with high acceleration will be corrected (when executing positioning jobs). A value '0' in P1037 disables the backlash function.

The backlash correction-function depends on the running direction. Parameter P147 (homing parameter - homing direction) defines the 'backlash direction'.

- when positioning into positive direction (and P147=4 homing into negative) the motor first runs the distance 'W minus backlash' with velocity 'V' into positive direction and afterwards the distance 'backlash' with velocity P1003 into the same (positive) direction.
- when changing direction (positioning job into negative direction), the drive first runs the backlash distance stored in P1037 with velocity P1003 into the positioning direction (negative direction). Then it executes the distance 'W' with the velocity 'V' into the same (negative) direction. At last the drives returns to the opposite direction (positive direction) and runs the backlash distance with the P1003-velocity.

WSERS Backlash-function

Timing Diagram when executing a positioning job (command "E")

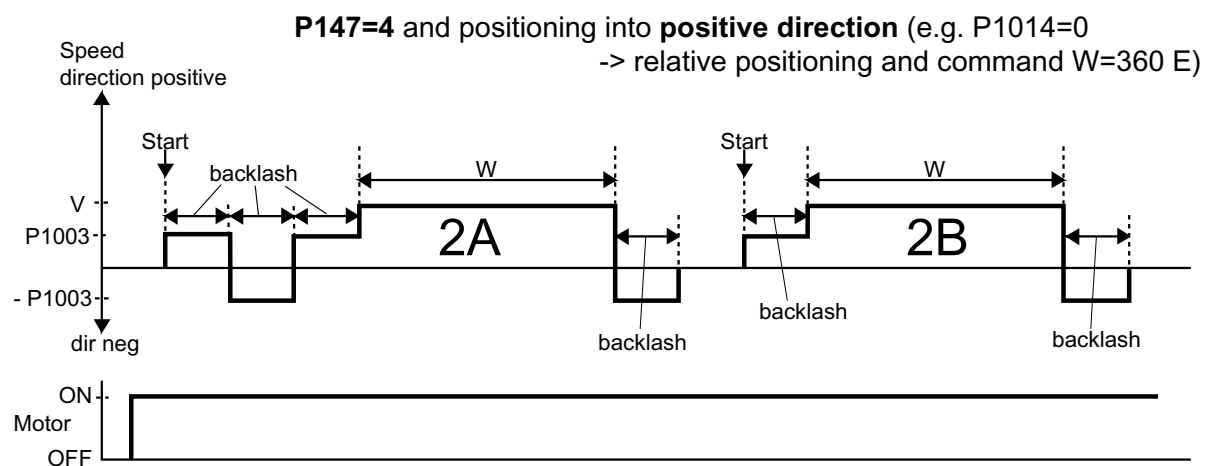
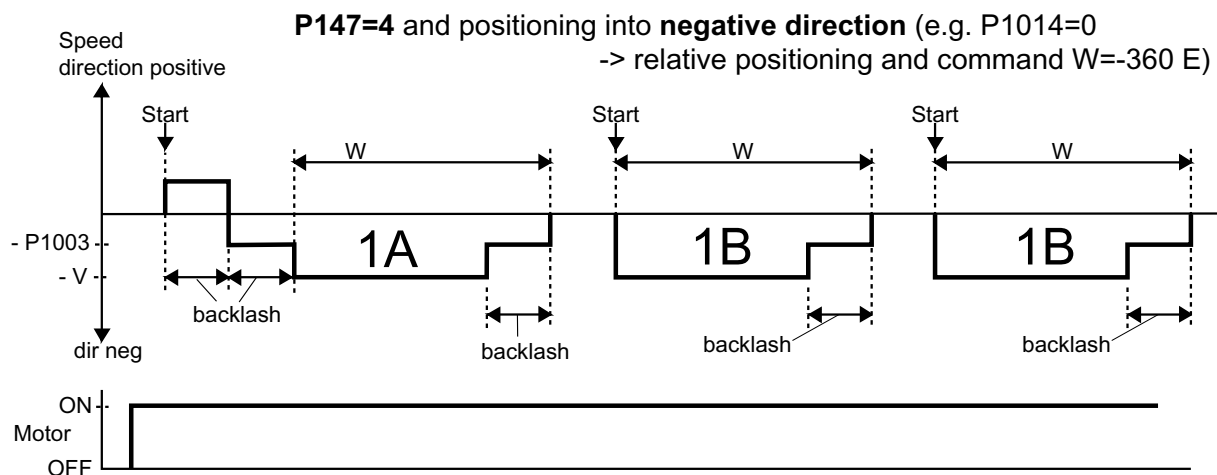

P147=5 and positioning into **positive direction** : running characteristics **1A** and **1B**

P147=5 and positioning into **negative direction** : running characteristics **2A** and **2B**

Backlash function when positioning and before executed manual drive command:

Depending on the executed manual drive function and the covered distance at manual driving (in relation to the backlash distance), the running characteristics 1A or 2A (depending on the direction and P147) or a different running characteristics is executed (e.g. positioning to the position command value only with backlash-velocity, if the covered distance with manual driving is smaller than the backlash value).

4.8.5 Parameters for programming

4.8.5.1 Time delay

Time delay

P1100 (D)

Alternative syntax : D

Indication in $\frac{1}{10}$ seconds = 100ms (D=1)

Minimum programmable delay: 10ms (D=0.1)

Example.: **D=20** → 2 seconds delay or **D=0.5** → 50ms delay

4.8.5.2 Counter

Counter 1 – unsigned 16 bit counter (0 until 65536)

P100 (C1)

Alternative syntax : C1

In case P1014=3 (relative positioning with overflow counter), then C1 is signed (-32768 until 32768) and it will be used as overflow counter.

Counter 2 – unsigned 16 bit counter (0 until 65536)

P101 (C2)

Alternative syntax : C2

Counter 3 - unsigned 32 bit counter (0 until $4,295 \times 10^9$)

P102 (C3)

Alternative syntax : C3

Counters together with IF-requests can be used for programming loops.

E.g.: #C1=20

#L1

Instruction block

#IF C1>1

#GOTO 1

In the example the *instruction block* will be executed 20 times.

4.8.5.3 Marker

Marker 1

P1101 (M1)

Alternative Syntax : M1

Marker 2

P1102 (M2)

Alternative Syntax : M1

Marker 3

P1103 (M3)

Alternative Syntax : M1

Markers may be set and reset any time in a executable program.

Markers may be used as events in IF-requests.

E.g.: #M1=1

#L1

Instruction block

#IF M1=1

#GOTO 1

In the example the *instruction block* will be executed as long as the marker P1101 is set.

4.8.5.4 List options

List options

P1028

For listing the E²Prom-program with the command 'LIST', different options may be selected. Following Bits are assigned in the 8-Bit value P1028:

- Bit 0 (decimal 1) : The number of the instruction (line number) will be listed
- Bit 1 (decimal 2) : units will be listed
- Bit 2 (decimal 4) : listing with offset of lines - labels will be listed in the 1st row and instructions will be listed in the 4th row
- Bit 3 (decimal 8) : Carriage Returns within the program will be listed in the same way the user programmed them (else each instruction will be printed in an separate line)
- Bit 4 (decimal 16): When sending 'LIST P' the parameter texts are listed too

E.g.: 'P1028=5' results in listing all instructions of the program in the E²Prom with line numbers when sending the command 'LIST' writing labels in the 1st row and instructions in the 4th row (P1028=5=1+4 , → Bit 0 and Bit 2 will be set).

4.8.5.5 Special Master-mode parameter

Wait until end of positioning

P1110

When the master is executing a positioning job, it will wait (depending on parameter P1110) until the end of the positioning job, before it continues with the next instruction of the program.

- 0 : No waiting for the end of a positioning job - in this way the master is able to control other axis while executing its own positioning job
- 1 : Wait for the end of the actual positioning job

Please note :

After Power On of the WSERS always P1110 = 1 !

The parameter P1110 can not be stored into the parameter section of the E²Prom.

Destination address

P1

(alternative syntax : z)

destination drive address - slave address - used only from the master drive

destination for assignments, commands and 'IF'-requests

(e.g. Z=3 -> following commands are sent to drive address 3)

IF send/receive

P2

IF' send/receive will be initiated by the master drive. The master drive sends an assignment to a slave drive. The operand is the requested event. The slave returns the value of the event as assignment to the master.

P2 is used internally. (e.g. 'P2=336' is equivalent to 'IF 336' after addressing a slave drive).

4.8.6 Miscellaneous parameters

4.8.6.1 Phase current adjustment

Commuting table

P1009

Selection of the current characteristics for the stepping motor current.
The characteristics to be chosen depends on the used stepping motor.
The better the current characteristics matches the motor-characteristics,
the softer and less noisier the stepping motor runs at low speed ranges.

Following selections are available:

- 0 : sinus-characteristics (pure sinus current)
- 1 : '87 style – characteristics (adjusted to the STÖGRA stepping motor-series SM 87)
- 2 : characteristics 3 (sinus² – characteristics)
- 3 : characteristics 4 (damped sinus² – characteristics)
- 4 : half step characteristics
- 5 : full step characteristics

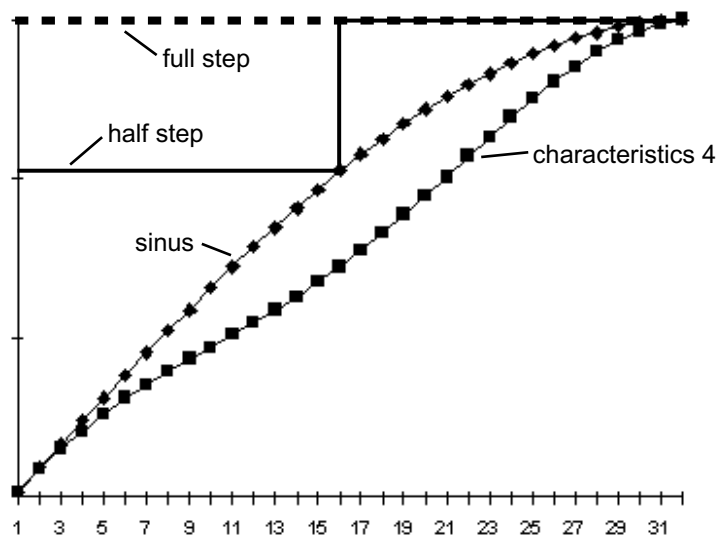

The '87' – characteristics and the Characteristics 3 are between the sinus characteristics and the characteristics 4.

Recommended current characteristics to be selected for STÖGRA-stepping motors :

- series SM 56 : '87'-characteristics
- series SM 87 : '87'-characteristics
- series SM 107/108 : characteristics 4
- series SM 168 : characteristics 4

32 corresponds to an angle of 1,8 ° at the stepper motor

Phase current

P1010

The unit of the assigned values is [mA]

The unit may not be assigned.

The valid range of values respectively the max. value which can be set, depends on the SERS version.

SERS 01	SERS 02	SERS 03	SERS 06	SERS 12	WSERS 04	WSERS 06	WSERS 08
[mA] 1400	2800	4200	8400	14500	4000	6000	8400

e.g.: '#P1010=6000' sets the phase current to 6A (=6000mA)

Acceleration value for current boost

P1012

The unit depends on the scaling mode for acceleration (P160).

In case of a set bit 2 in P1011 the phase current will be risen during accelerating, if the value stored in P1012 is exceeded - P1012 may not be chosen smaller than 10 rad/s².

current parameters**P1011**

Following assignment bit by bit apply (the explanations are valid for bits set) :

- Bit 0 (decimal 1) : automatic **current reduction** at motor stop is active
When the motor stops, the phase current will be reduced to 50% of the value stored in P1010.
- Bit 1 (decimal 2) : automatic **current boost** is active -for getting more torque for acceleration
When the acceleration value stored in P1012 is exceeded during accelerating, then the phase current will be increased by 20%.
- Bit 2 (decimal 4) : Current boost is active at motor stop
When the motor stops the phase current will be increased by 20%
- Bit 3 (decimal 8) : switch to full step characteristics during accelerating for getting max. accelerating torque (depends on P1012, as Bit 1 above)

E.g.: '#P1011=3' results in reducing automatically the phase current by 50% when the motor stops and rising the phase current by 20% during accelerating (depending on P1012).

current range**P1034**

may not be changed - set by factory !!!

- 1 : 1A-versions - e.g. SERS 01.60 V03
- 2 : 2A-versions - e.g. SERS 02.24 V03
- 3 : 3A and 4A/WSERS-versions - e.g. SERS 03.24 V03 oder WSERS 04.80 V01
- 4 : 4A/WSERS-versions - e.g. WSERS 04.230AC V01
- 5 : 4A-versions - e.g. SERS 04.60 V03
- 6 : 6A and 8A/WSERS -versions - e.g. SERS 06.85 V03 oder WSERS 08.80 V01
- 7 : 6A/WSERS-versions - e.g. WSERS 06.230AC V01
- 12 : 12A-versions - e.g. SERS 12.120 V03

4.8.6.2 Program continue after Stop**Continue after Stop****P1033**

The parameter defines, how to continue in the program respective with a positioning job after an one time Stop-command (sent via serial interface) or Stop-Signal (at input I9) and then again a Start-command or signal (sent /input I8).

Following possibilities can be selected :

- 0 : **New start** of the program in the E²Prom (Start at line 1) respective new complete execution of the value in W (P47) in case of relative positioning.
- 1 : After one time Stop : Continuing of the program at that point, where it was interrupted, respective continuing the interrupted positioning job.
After two times Stop: proceed as described for P1033=0
- 2 : Jump to Label L65 in the program (after a stop-command or if there is an error, which causes a program termination – for possible errors see description parameter P11
- 3: as 2 but after a jump to L65 all further errors will not result in a program stop or a further jump to L65, until the internal flag "L65 error handling" is reset by the command "P1118=0" or "P11=0".

Flag - L65 error handling**P1118**

Possible values:

- 0 : End of L65 error handling , it may be jumped again to L65
- 1 : L65 is executed

4.8.6.3 Manual drive control commands

Manual drive control - command

P1031

Different manual drive functions can be executed by assigning P1031 as follows :

- 1 : Left - slow (alternative syntax : **LS**)
- 2 : Right - slow (alternative syntax : **RS**)
- 4 : Left - fast (alternative syntax : **LF**)
- 8 : Right - fast (alternative syntax : **RF**)
- 16 : Homing (alternative Syntax : **H**)

Stop when manual driving (jog)

P1093

In case a manual drive (jog) function is activated at a digital Input (I 1 until I 6) , and a E²Prom-operational program is active, then the reaction of the SER drive depends on P1093 as follows:

- 0 : the operational program will be interrupted and the jog function will be executed.
After deactivating the jog input the operational program will be continued.
- 1 : the operational program will be terminated and the jog function will be executed.
After deactivating the jog input the operational program will **not** be continued.

Manual drive (jog) functions at Power-ON

P1095

If manual drive functions are enabled (via P1021 or service-switch) with P1095 it is specified, how to react after a Power-ON-Reset (voltage supply ON).

- 0 : Start jog function if there is a **static signal** at the (jog) input
- 1 : Start jog function only if there is **signal edge** to '1' at the (jog) input

4.8.6.4 Manual drive control with Timeout

Manual drive with Timeout

P1035

If a manual drive function was started by sending one of the manual drive commands LS,RS,LF,RF or by assigning the parameter P1031 as described above, then depending on the parameter P1035 the manual drive function will be stopped again, if the manual drive command is not repeated latest 500ms after the last command.

The parameter is "1" by factory setting. When operated with a SERS-Programmer this transmits the jog command every 500ms again to the WSERS, as long as the corresponding key of the jog function is pressed at the SERS-Programmer (e.g. "RS" for "jog right slow").
ATTENTION: Parameter P1035 cannot be saved into the EEPROM of the WSERS!

After each Power-ON (switching on the voltage supply of the WSERS) P1035 is always set to "1" (jog will be stopped automatically after 500ms).

Therefore for an operation of the WSERS with e.g. a PC (in serial mode) parameter P1035 must be set to "0" (P1035=0) always after switching on the power supply (Power-ON), if jog commands shall be used.

- 0 : no timeout when using manual drive functions
- 1 : timeout manual drive is active - max. after 500ms a manual drive function will be stopped

4.8.6.5 Drive address

Drive address

P1050

The WSERS stores the drive address selected at DIP switch 2 (see 3.1.1 page 13) in parameter P1050.

4.8.6.6 Control of load angle

Control of load angle assignment error/warning

P1029

Definition of the reaction of the SERS in case of a load angle error

0 : no reaction - without control of load angle

1 : Message drive error - control of load angle (see P11)

2 : Message warning - control of load angle (see P12)

3 : Message drive error - control of load angle (P11) - but motor current stays ON

Parameter values '1' to '3' for P1029 work only if option E50 – SERS... E50 ... (e.g. SERS 06.85 V02 E50) is installed and the stepper motor includes a 2-channel incremental encoder.

P1029<>0 means controlling the load angle of the stepper motor. The position command value is compared with the real motor position. If the allowed max. load angle is exceeded then a warning or an error is created.

If P1053 = 4 or P1053 = 8, then not only the exceeding of the load angle is detected, but additionally the real motor position – see P1053.

Option Input pulse / electrical gearing / hand wheel / input encoder / control of load angle with correction of position / frequency measurement

P1053

0 : Function disabled.

1 : Pulses at digital Input I 3 move the motor

2 : as 1, but additionally with direction signal at digital Input I 4 (active = negativ)

3 : Type SERS ... (without option E50):

Pulses at digital Input I 3 -> motor moves into positive direction,

Pulses at digital Input I 4 -> motor moves into negative direction,

Type SERS ...E50... (including option E50):

Encoder signals – signal A at Input I 3 and Signal B at Input I 4 → motor is moved by encoder signals. Evaluation of direction automatically from encodersignals A and B

4 : Control of load angle – connection of a 2-channel-encoder :

channel A at digital Input I 3 and channel B at digital Input I 4

5 : as 1, but encoder input (9-pole D-Sub-connector "ENC") instead of digital input

6 : as 2, but encoder input (9-pole D-Sub-connector "ENC") instead of digital inputs

7 : as 3, but encoder input (9-pole D-Sub-connector "ENC") instead of digital inputs

8 : Control of load angle – connection of a 2-channel-encoder with signals A and B and inverted signals /A and /B at 9-pole D-Sub-connector "ENC"

9 : for SERS ... (without option E50) – input for frequency measurement

the frequency of pulses at digital input I 3 are measured (result can be read in P1124)

P1055 defines the timer interval for the measurement

10: Frequenzmessung über Drehgebereingang an 9-pol. D-Sub-Buchse "ENC" (Ergebnis in P1124). Die Frequenz wird unabhängig von der Drehrichtung immer positiv ausgegeben.

Auswertung von A, /A, B und /B. Mit P1055 wird das Zeitmess-Intervall bestimmt

Handwheel / electrical gear (P1053=3 or P1053=7):

The motor follows the encoder pulses of a handwheel or of a 'leading' axis (motor).

While following the encoder pulses the acceleration and the velocity of the drive are limited by the parameters **A (P138)** and **V (P91)**. If an "error limit switch" occurs (e.g. limit switch left opens) the motor stops and the phase current will be switched off. Afterwards moving the handwheel or the 'leading' axis into the opposite direction (e.g. right direction), will switch on the motor current again automatically and the motor follows the encoder signals again - see also parameter P1094.

Control of load angle (P1053=8 or P1053=4) with detection of real motor position:

P1053=4 normally is not good for the control of load angle, because for a safe control of load angle the inverted signals /A and /B should be evaluated too. Only in exceptional cases **P1053=4** should be used.

For the control of load angle always the option **P1053=8** should be used !

Additionally to **P1053=8** the parameter **P1029** must be set to a value $\langle 0$ (see **P1029**)

In case of an "error load angle" (**P11=32** or **P12=32** – depending on **P1029**) – the motor lost its position due to a mechanical overload – following commands can be used

- 'POSR' : the motor will be moved with homing velocity (**P41**) to the actual position command value (parameter 'W' - **P47**) – see also parameter **P1043**
- 'P11=0' or 'P12=0' : the real motor position (detected by the encoder signals) will be written into parameter **P51** (position of the stator field).

After a mechanical overload the SERS can detect (count) a max. load angle error (difference between position command value and physical motor position) of +/- 32768 increments.

In case of encoder type E50 (2 x 50 pulses per rev. and 4-times evaluation → 200 pulses per rev.) it can be detected (and corrected by command "POSR") max. 163.8 revolutions.

Scaling factor input pulses**P1054**

This parameter specifies the resolution of the connected encoder or the required step width per pulse (e.g. in case of **P1053=1**) - unit: 1/200 rev.

- unit: 1/200 Umdr.

- 16 bit value with 5 decimal points

- value range -32.76800 until 32.76700

internally there are stored only 16 bit. At values out of the range [-0.32768 , 0.32767]

the resolution will be reduced by setting the last two decimal points to 0 (e.g. 21.54700)

Examples: **P1054=2.5** for an encoder with 2 x 20 pulses per rev. e.g. encoder "E20"

P1054=1 for an encoder with 2 x 50 pulses per rev. e.g. encoder "E50"

P1054=0.25 for an encoder with 2 x 200 pulses per rev. e.g. encoder "H200"

P1054=0.05 for an encoder with 2 x 1000 pulses per rev.

Time slot for frequency measuring**P1055**

Indication in multiples of 2ms - For the function handwheel / electrical gear :

defines the time interval for counting the pulses for calculating the velocity command

value of the drive. **P1055=1** means that every 2ms the counted pulses result in a new

velocity command value. A larger value - e.g. **P1055=50** (interval 100ms) - results in a

smother running of the motor at low speed when following the encoder pulses.

At **P1053=9** the parameter **P1055** defines the time interval for the frequency measurement.

→ e.g: At **P1055=50** every 100ms the pulses at input I3 are counted. The counting result after one time interval can be read in parameter **P1124**.

Max. load angle (for internal use only)**P1057****Controlled value load angle****P1002**

Limit value of load angle – when the load angle exceeds this value, then an error load angle will be created.

Non scaled value – Indication in increments (unit 1/12800, 12800 increments = 360°)

Standard value : 7,2° degree (in case of 1,8° stepper motor)→ **P1002=255**

Frequency at P1053=9**P1124**

Frequency measurement result at **P1053=9**, unit: counted pulses / **P1055** (time interval)

Overview functions P1053

Control of load angle

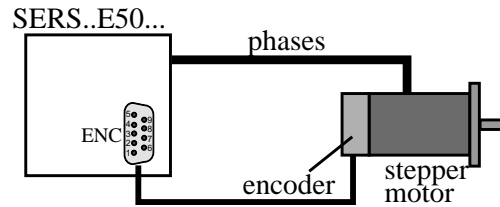

Necessary parameters:
P1053 : 0 or 8
P1029 : 1 or 2 or 3
Possible command **POSR**

Function handwheel / electrical gear

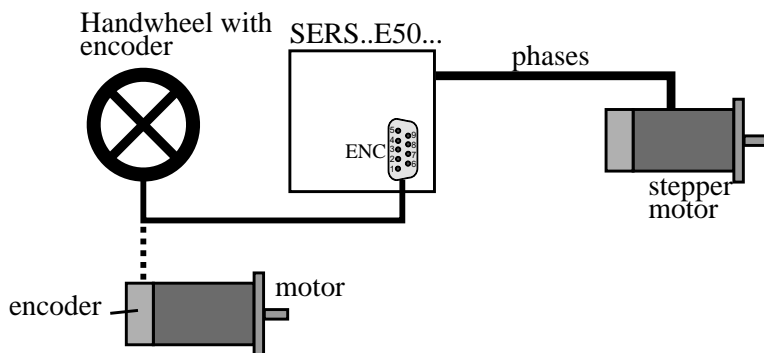

Necessary parameters:
P1053 : 3 or 7
P1029 : 0

Control of load angle and function handwheel / electrical gear

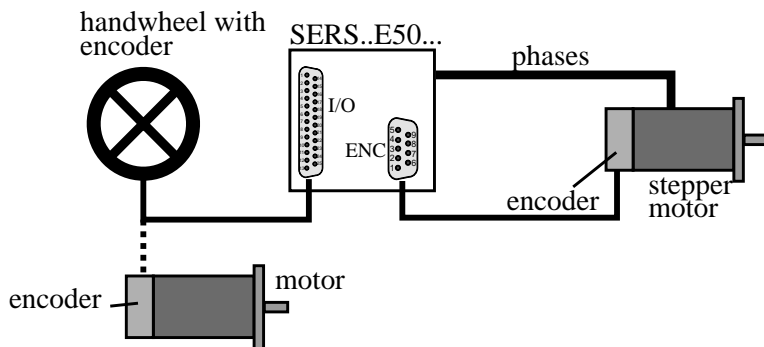

Necessary parameters:
P1053 : 3 or 7
P1029 : 1 or 2 or 3
Command **POSR** not possible

Pulses input

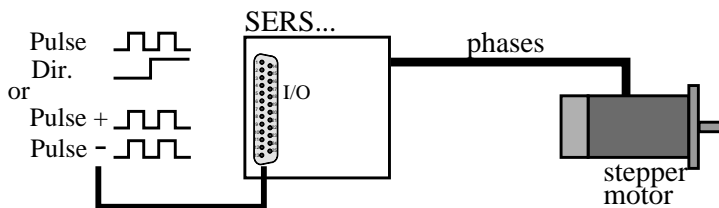

Necessary parameters:
P1053 : 1 oder 2
P1029 : 0

Option Pulse Input / Electrical Gearing Function / Hand wheel / Encoder input / Load angle control with correction of position / Frequency measurement **P1143**

0 : function disabled

1 : Pulses at digital input I 3 result in moving motor (stepper driver clock input)

2 : as 1, but additionally with direction at digital input I 4 (aktive = negative direction)

3 : Pulses at digital input I 3 result in moving into positive direction

Pulses at digital input I 4 result in moving into negative direction

4 : Load angle control - connection of a 2-channel-encoder :

Channel A at digital input I 3 and channel B at digital input I 4

(P1002: if the max. load angle - saved into P1057 - exceeds the value in P1002, then a load angle error will be created – depending on P1029)

5 : Pulses at digital input I 3 are measured as frequency (result in P1146)

Scaling factor input pulses **P1144**

Definitions as P1054, but regarding to P1143 (pulses at I 3 and I 4)

Time slot for frequency measuring **P1145**

Definition wie P1055, aber bezogen auf P1143 (Pulse an I 3 und I 4)

Frequency at P1143=5 **P1146**

Frequency at P1143=5

Unit: Pulses / P1145 (time slot)

Pulse input counter 3 **P1147**

Used internally and should not be written!

Reading out or erasing pulse input counter 3 (encoder interface with option “E50“).

In case of writing P1147 an electrical gearing function (at P1053=7) may receive new command values, what results in a not planned drive reactions (movements).

Keep absolute value in case of error limit switch and function electrical shaft / handwheel **P1094**

In case of P1053=3 or P1053=7 if the motor moves on a limit switch (when controlled by the external encoder signals), then the drive will be stopped and the motor phase current will be switched off. If afterwards the external encoder signals are into the opposite direction, then depending on P1094 the motor reacts as follows:

0 : encoder signals into the direction of the open limit switch will be ignored. Encoder signals into the opposite direction result in switching on the phase current and following of the motor to the encoder signals.

1 : encoder signals, into the direction of the open limit switch are not executed, , but will be counted internally (increment the counter). Encoder signals into the opposite direction result in decrementing the internal counter . If the counter is ‘0’, then the motor phase current will be switched on and the motor follows the encoder signals. So the motor position is always identically (proportionally) to the position of the handwheel (or leading axis in case of encoder signals from an other ‘leading’ motor).

Pulse input counter 1**P1119**

Is used internally for the P1053 modes and contents the actual count.

→ do not overwrite, because else in case of activated functions electrical gearing / pulse input the motor could receive new position command values !

Pulse input counter 2**P1120**

Definition as P1119

4.8.6.7 Control of motion**Motion control****P1044**

Running distance value (scaled value depending on P76).

When running, after covering this distance there must be a signal (edge 0 → 1 with high-active input signals or edge 1 → 0 with low-active input signals) at the input specified in P1045.

e.g.: P1044 = 10mm and P1045 = 2

When during running there is not a signal edge at the input I2 at least all 10mm then the drive will stop and the error bit 'motion control' in P11 will be set.

Motion control – assignment input for control**P1045**

Definition of the input used for the motion control - see P1044

P1045 = 1 → input I1

P1045 = 2 → input I2

⋮
⋮

P1045 = 8 → input I8

4.8.6.8 Handshake mode**Handshake mode****P1017**

0 : V24-handshake mode - the pins 2,3,5,7,8 at the 9-pole

serial PC-COM-connection must be connected

- hardware-handshake (using of pins 7 and 8)

- each received character will be returned 1:1

1 : no hardware handshake - the pins 2,3,5 at the 9-pole

serial PC-COM-connection must be connected

- each received character will be returned 1:1

2 : RS485-handshake - no hardware-handshake

- received characters are not returned

- error messages are sent only after a received end of line (Carriage Return)

(see also page 24 - syntax general notes)

4.8.6.9 E²PROM-Parameter

E²PROM Parameter

P1004

Following values can be selected :

2 : Save the actual parameter in the SERS-RAM into the E²PROM

alternative syntax : **PSAVE**

Please note : Changed parameters in the SERS are stored into the SERS E²PROM only by sending P1004=2 or **PSAVE** !

Before sending **PSAVE**, the actual parameters are only in the SERS-RAM, that means that after switching off the SERS (disconnecting from power supply) without **PSAVE** all parameter changes are lost !!!

3 : Write standard parameter values in E²PROM

ATTENTION ! : By sending **P1004=3** to the SERS all actual parameters stored in the E²PROM will be erased and replaced by standard values (pre-selected values) !!!

4 : Save actual position (P51) into E²PROM

alternative syntax : **POSSAVE**

5 : Save register R0 until R5 and W into E²PROM

Save R0 until R5 and W

P1117

Possible values to be written:

0 : disabled (=standard adjustment)

1 : Save also parameters "R0" until "R5" and "W" into E²PROM with the command P1004=2 ("PSAVE")

Free E²PROM memory

P1122

Indicates the actual free program memory in the E²Prom

Indication in words (1 word = 2 bytes)

500µs programm mode

P1127

Switching mode for compatibility to SERS ... V01 - V03 controls.

P1127=1

Executing of operational programs in the EEPROM will be reduced to 500 commands per second (2ms cycle time). Also the velocity of evaluating and executing commands received and sent via the RS232-interface is reduced to 2ms per command.

P1127=0

The time for executing commands in operational programs and the RS232 interface is 500µs.

4.8.6.10 Language selection

Language selection

P265

0 : German

1 : English

4.8.6.11 Software limit switch / position limit

Position limit negative P1040

scaled value (depends on P76)

When running into negative direction and the actual position (P51) is smaller than this value P1040, then the drive stops, the bit "limit position" in P12 (warnings) is set, P1042 is "1" and the 7-Segment-displays shows a blinking "L".

Position limit positive P1041

Definition as P1040 but positive drive direction

4.8.6.12 Arithmetic Parameters

Accumulator P1047

Alternative Syntax : **X**

Variable for all arithmetic-functions - all calculations have to be done via the accumulator X - see also chapter arithmetic page 38

Example:

$X = V - ADC * P1080$

Register 1 P1080 (R0)

Alternative syntax : **R0**

Free usable 32 bit signed variable

e.g. for saving results of arithmetical operations

Register 2 P1081 (R1)

Alternative syntax : **R1** - see P1080

Register 3 P1082 (R2)

Alternative syntax : **R2** - see P1080

Register 4 P1083 (R3)

Alternative syntax : **R3** - see P1080

Register 5 P1084 (R4)

Alternative syntax : **R4** - see P1080

Register 6 P1085 (R5)

Alternative syntax : **R5** - see P1080

4.8.6.13 Service switch external

Service switch external P1092

0 : disabled

1 : if there is an active signal at the opoisolated input 'service switch external', then the digital inputs I 1 to I 8 are enabled for the manual drive functions – see description 'Enable manual drive functions' at page 15 (chapter 3.1.4). The 'service switch external' can be used alternatively to the 'service switch' at DIL-switch 1 Bit 6 (chapter 3.1.4).

4.8.6.14 Program-/Parameter-Masken and Password for SERS-Programmer

Password definition

P1059

In P1059 there can be defined any password - 4-digit number - as password to enable showing and changing parameters and the E²Prom-program in the SERS when operating with the SERS-Programmer !

P1059=0 means, that there is no password defined and all parameters and program lines may be seen and changed without password.

In case of the definition of a password :

If the password is not entered correctly when operating the SERS with the SERS-Programmer (e.g. just enter the RET-key when being asked for the password) then only the parameters enabled in P1060 until P1065 and the program lines enabled in P1070 until P1073 are displayed .

When entering the password correctly in the SERS-Programmer , then the operator can see and edit all parameter and the complete program.

Parameter Mask [0]

P1060

Enable the parameters P0 until P103 - set bit means enabled and the parameter can be seen and edited by the SERS-Programmer also without knowing the password in P1059.

P0	P1	P2	P11	P12	P41	P42	P44
1	2	4	8	16	32	64	128
P47	P51	P76	P91	P100	P101	P102	P103
256	512	1024	2048	4096	8192	16384	32768

e.g: P1060 = 2144 (=32+64+2048) → parameters P41, P42 and P91(V) will be displayed in the parameter section of the SERS-Programmer and can be edited even without knowing the password, defined in P1059.

Parameter Mask [1]

P1061

Explanation as P1060 and valid for following parameters:

P108	P121	P122	P123	P134	P138	P147	P160
1	2	4	8	16	32	64	128
P265	P336	P403	P1001	P1002	P1003	P1004	P1005
256	512	1024	2048	4096	8192	16384	32768

Parameter Mask [2]

P1062

Explanation as P1060 and valid for following parameters:

P1006	P1007	P1008	P1009	P1010	P1011	P1012	P1013
1	2	4	8	16	32	64	128
P1014	P1015	P1016	P1017	P1018	P1019	P1020	P1021
256	512	1024	2048	4096	8192	16384	32768

Parameter Maske [3]**P1063**

Explanation as P1060 and valid for following parameters:

P1022	P1023	P1024	P1025	P1026	P1027	P1028	P1029
1	2	4	8	16	32	64	128
P1030	P1031	P1032	P1033	P1034	P1035	P1036	P1037
256	512	1024	2048	4096	8192	16384	32768

Parameter Maske [4]**P1064**

Explanation as P1060 and valid for following parameters:

P1038	P1039	P1040	P1041	P1042	P1043	P1044	P1045
1	2	4	8	16	32	64	128
P1046	P1047	P1050	P1051	P1052	P1053	P1054	P1055
256	512	1024	2048	4096	8192	16384	32768

Parameter Maske [5]**P1065**

Explanation as P1060 and valid for following parameters:

P1056	P1057	P1058	P1059	P1060	P1061	P1062	P1063
1	2	4	8	16	32	64	128
P1064	P1065	P1066	P1070	P1071	P1072	P1073	P1080
256	512	1024	2048	4096	8192	16384	32768

Parameter Mask [6]**P1066**

Explanation as P1060 and valid for following parameters:

P1081	P1082	P1083	P1084	P1085	P1092	P1093	P1094
1	2	4	8	16	32	64	128
P1095	P1096	P1097	P1098	P1099	P1100	P1101	P1102
256	512	1024	2048	4096	8192	16384	32768

Parameter Mask [7]**P1067**

Explanation as P1060 and valid for following parameters:

P1103	P1110	P1111	P1112	P1113	P1114	P1115	P1116
1	2	4	8	16	32	64	128
P1117	P1118	P1119	P1120	P1121	P1122	P1123	P1124
256	512	1024	2048	4096	8192	16384	32768

Parameter Mask [8]**P1068**

Explanation as P1060 and valid for following parameters:

P1125	P1126	P1201	P1202	P1203	P1204	P1205	P1206
1	2	4	8	16	32	64	128
P1207	P1208	P1209	P1210	P1211	P1212	P1213	P1214
256	512	1024	2048	4096	8192	16384	32768

Program Mask [1]**P1070**

By using the program mask there can be enabled specific program lines (only value assignments) in the E²PROM-Program when using a SERS-Programmer. The enabled program lines (value assignments) will be displayed in the program-menu of the SERS-Programmer and can be edited, even if the password, defined in P1059, was not entered correctly in the SERS-Programmer.

Following rules apply :

- Enabling a program line refers to a Label. (e.g. L1 or L23)
- The Label L1 until L64 may be enabled
- The by the Label followed assignment is enabled (e.g. L1 V=1000)
- Only value assignments may be enabled together with Labels
- If there is an additional TEXT-string (defined through quotation marks) between the enabled Label and the value assignment (e.g. L1 "velocity" V=1000), then this TEXT-string will be displayed, too

Example: Following program is stored in the E²PROM of the SERS:

```
P1014=0
L1
A=2000.000
L2
"Velocity:  "
V=500.000
W=1300 E
```

The Label L1 and L2 are enabled with P1070=3 (=1+2)

When using the SERS-Programmer without entering the correct password (or just entering the RET-Taste when asked for the password) then following program lines will be displayed:

```
A=2000.000
Velocity:
V=500.000
```

NOTES to TEXT-strings:

When using a TEXT-string - defined through the quotation marks " at the beginning and the end of the text, then the length of the text should be exactly 16 characters, because the SERS-Programmer does not insert automatically a carriage return at the end of the text - the display of the SERS-Programmer is 4 x 16 characters. In that way the text and the following value assignment will be shown at the display of the SERS-Programmer in separate lines.

The text can be filled with space characters.

e.g.: "length " - to the text 'length' are added 10 space characters.

L1	L2	L3	L4	L5	L6	L7	L8
1	2	4	8	16	32	64	128
L9	L10	L11	L12	L13	L14	L15	L16
256	512	1024	2048	4096	8192	16384	32768

e.g.: P1070=42 (=2+8+32)→ Labels L2, L4 and L6 are enabled

Program Mask [2]**P1071**

Explanation as P1070 for following program Label:

L17	L18	L19	L20	L21	L22	L23	L24
1	2	4	8	16	32	64	128
L25	L26	L27	L28	L29	L30	L31	L32
256	512	1024	2048	4096	8192	16384	32768

Program Mask [3]**P1072**

Explanation as P1070 for following program Label:

L33	L34	L35	L36	L37	L38	L39	L40
1	2	4	8	16	32	64	128
L41	L42	L43	L44	L45	L46	L47	L48
256	512	1024	2048	4096	8192	16384	32768

Program Mask [4]**P1073**

Explanation as P1070 for following program Label:

L49	L50	L51	L52	L53	L54	L55	L56
1	2	4	8	16	32	64	128
L57	L58	L59	L60	L61	L62	L63	L64
256	512	1024	2048	4096	8192	16384	32768

4.8.6.15 CANopen Parameter

Operand

P1097

For use with SERS-versions with CANopen interface → SERS...CAN

Operand for the Opcode defined in P1099.

An assignment to this parameter will not be saved into the E²PROM, but executed immediately (only 32 bit assignments).

Opcode

P1099

For use with SERS-versions with CANopen interface → SERS...CAN

An assignment to this parameter will not be saved into the E²PROM, but executed immediately (only 32 bit assignments).

The value of these parameter will be assigned to the Opcode.

In the programming mode (started through P0=2 → new) the Opcode will be saved.

In the normal (non programming) mode the Opcode will be executed.

In case of Opcodes, which require a Operand, the Operand must be defined before in P1097.

E.g. a "RUN 5" Opcode will be executed as "P1099=62213".

A "E" Opcode will be executed as "P1099=63235".

For writing an operational program with a SERS...CAN with CANopen-interface for saving it into the SERS E²PROM the parameters P1097 und P1099 must be used.

4.8.6.16 Profibus Parameter

Profibus-ID

P1142

0: (default) use ID from versions SERS V01 to SERS V03 (ID = 0008)

1: use new Profibus-ID (ID=07B5)

For "old" existing projects, where Id-Nr. "0008" was used when setting up the Profibus projekt (using GSD-files "STOEGRA3.gsd" until "STOEGRA5.gsd"), parameter P1142 must be set to "0" (P1142=0).

For new projects, when using "STOEGRA6.gsd" or newer GSD-files, parameter P1142 must be set to "1" (P1142=1).

5. Technical specifications

Protection of the device

WSERS : IP 21

Protection against over temperature, under voltage and protection against short circuit (phase against phase and phase against GND)

Weight

WSERS 04.80 : 0,4 kg , WSERS 08.80 : 0,77 kg , WSERS xx.230AC : 1,1 kg

Ambient conditions

Ambient temperature : 0°C to 50°C

Forced draft is necessary in case of following conditions:

Duty cycle >50% or current reduction at stand still disabled (see parameter P1011) and

- at WSERS 04.230AC and set phase current >3A
- at WSERS 06.230AC and set phase current >4A

Noise immunity

In case of correct installation : according to EN50082-2

Noise radiation

In case of correct installation and shielding of the leads : according to EN55011 class B

Voltage supply

WSERS 04.80 , WSERS 08.80 : 20 - 80 VDC (max. ripple 5%)

WSERS 04.230AC , WSERS 06.230AC : 230VAC / 50 - 60Hz

WSERS 04.115AC , WSERS 06.115AC : 115VAC / 50 - 60Hz

Phase currents

WSERS 04.80 : 0 – 4,2 A/phase

WSERS 08.80 : 0 – 8,4 A/phase

WSERS 04.115AC and WSERS 04.230AC : 0 – 4 A/phase

WSERS 06.115AC and WSERS 06.230AC : 0 – 6 A/phase

Inputs

2 limit switch inputs, 1 reference switch input, 1 Stop input:

Optoisolated inputs with common Opto-GND

Signal level : 13 VDC – 30 VDC

8 free programmable digital inputs

configurable Low or High active, TTL-level or SPS-level

optionally **additional 8 free programmable digital inputs** (only option I/O) with PLC-level

1 analogue input (at WSERS xx.230AC and WSERS xx.115AC optionally):

differential analogue input 0 - 5 VDC with 8 bit resolution

Outputs

1 potential-free ready signal - (2 relay contacts) - max. load 100mA / 50VDC

4 free programmable galvanic isolated PNP outputs – max. load 500mA / 5-24 VDC